

Manual for 20-I-Apparatus

8.0



REMBE® Research+Technology Center GmbH

Zur Heide 39, D-59929 Brilon, Germany

www.rembe-rtc.de info@rembe-rtc.de

Cesana AG

Baiergasse 56, CH-4126 Bettingen, Switzerland

www.cesana-ag.ch info@cesana-ag.ch

Authors: Christoph Cesana, Richard Siwek

Manual (this document)

1. Fundamentals
2. Software
3. Operation
4. Procedures for Dusts
5. Procedure for Hybrid Mixtures
6. Procedure for Gas (quiescent)
7. Utilities
8. Troubleshooting
9. Maintenance
10. References

Annex

1. Installation
2. Piezoelectric transducers
3. General test procedure
4. Cleaning the apparatus
5. Maintenance of outlet valve
6. Technics

Symbols



Please read this note!



Question Answer



Attention: Please read this safety instruction carefully!

1. Fundamentals

1.1 The field of applications of the 20-I-apparatus

1.1.1 Combustible dusts

Due to the less favorable surface to volume ratio, the explosion pressure P_{max} measured in the 20-I-apparatus is in general slightly lower than the one measured in the 1m^3 vessel. This is caused by cooling effects. Comparisons of pressure/time recordings also show that the pressure drop after the explosion is much faster in the 20-I-apparatus. Therefore a correction has to be made. In addition the pressure effect caused by the chemical igniters must be taken into account. With both (automatic) corrections, the P_{max} value measured in the 20-I-apparatus agrees excellent with those measured in the 1m^3 vessel.

The K_{max} values calculated from the rate of pressure rise correlate exactly with the K_{max} values obtained in the 1 m^3 vessel - within the accuracy of measurements - up to aluminum dusts ($K_{max} > 700\text{ m}\cdot\text{bar/s}$)

1.1.2 Flammable gases and solvent vapors

The minimum volume for the explosion testing of gas or solvent vapor / air mixtures is: $V = 1$ liters. Therefore, the 20-I-apparatus is also suitable for the explosion testing of gases and vapors.

1.1.3 Hybrid mixtures

"Hybrid mixtures" are dust/air mixtures containing flammable gases or flammable vapors in the combustible atmosphere. They are mixtures of two fold origin. These investigations of the explosion characteristics which are describing the explosion- and ignition behavior of such hybrid mixtures can also be determined with sufficient accuracy in the 20-I-apparatus; if the results are compared with the standard 1 m^3 vessel.

1.2 Determination of the explosion indices

The explosion overpressure P_m and the rate of pressure rise dP/dt describe the violence of reaction of dust/air mixtures of random concentration after ignition in a closed vessel. The maximum explosion pressure P_{max} and the maximum rate of pressure rise $(dP/dt)_{max}$ of combustible dusts are determined in closed standard equipment (e.g. 1-m³-vessel or 20-l-apparatus) by means of tests over a wide range of concentrations:

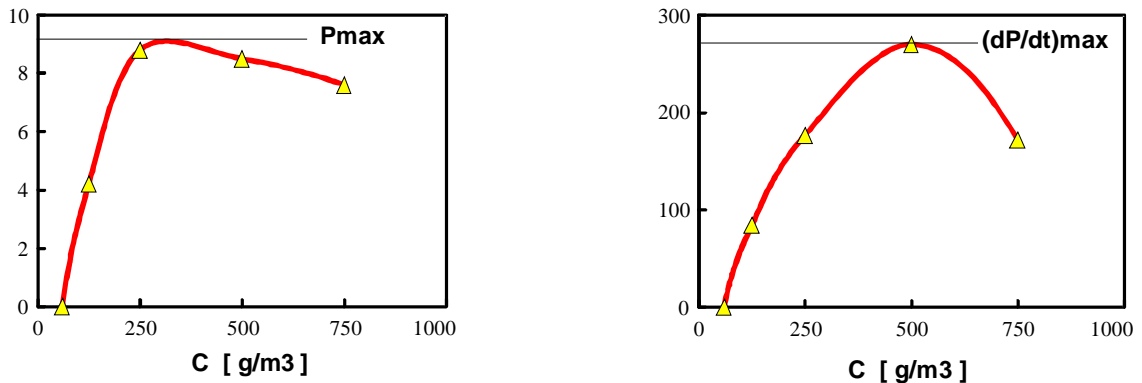

Fig. 1.2: Determination of the explosion indices and the lower explosible limit

With this test procedure, the lower explosible limit LEL can also be determined for dusts being tested. This LEL is important for risk evaluation in the chemical industry.

The maximum explosion pressure, when determined in closed, spherical or cubic vessels of sufficient size ($V \geq 20$ l) with central ignition source, is practically independent of the volume of the vessel.

But the maximum rate of pressure rise depends on the volume. It decreases with increasing volume. The K_{max} -value is dust and test method specific but independent of volume.

For the 20-l-apparatus the following equation applies:

$$0.02 [\text{m}^3]^{1/3} \times (dP/dt)_{max} [\text{bar/s}] = K_{max} [\text{m} \cdot \text{bar/s}]$$

The large number of dusts produced and handled in industry led to a classification of dusts, according to their K_{max} -values, into dust explosion classes:

Dust explosion class	K_{max} [m•bar/s]
St 1	> 0 - 200
St 2	201 - 300
St 3	> 300

1.3 Pressure course: Definitions

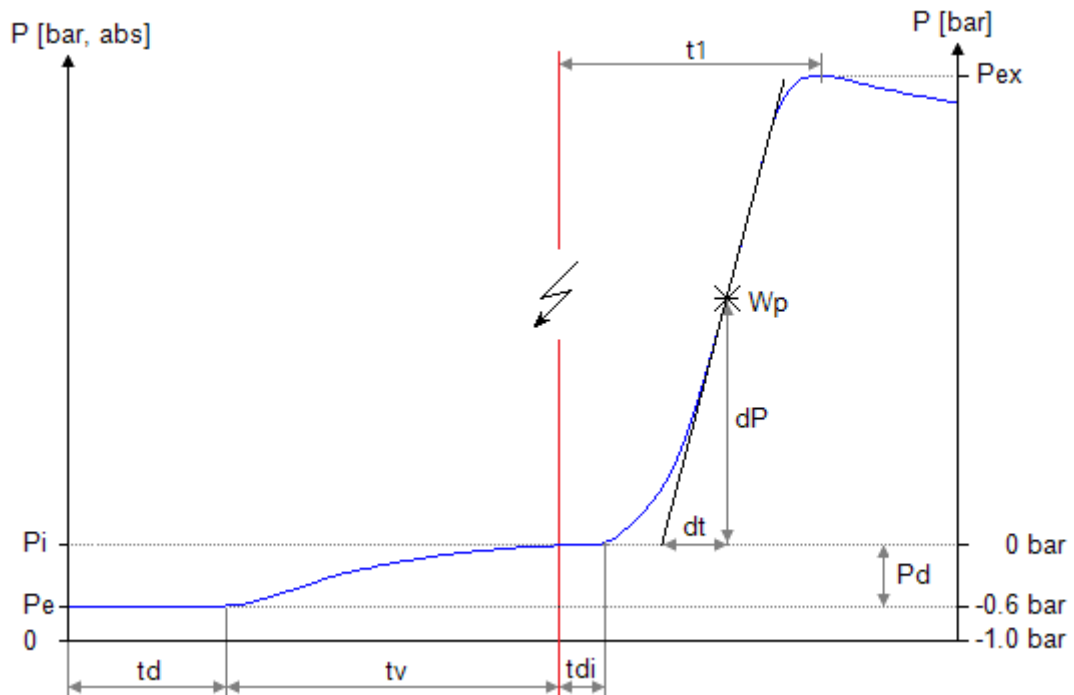

picture 1.3: Pressure/time-diagram of a fuel explosion

P_i	Pressure at time of ignition = normal pressure = 0 bar, overpressure
P_e	Pressure after evacuation of the apparatus = 0.6 bar,abs = -0.6 bar, overpressure
t_d	Time delay of the outlet valve = time difference between the electrical activation of the outlet valve and the first pressure rise in the apparatus.
t_v	Ignition delay time = time difference between the first pressure increase in the apparatus and the electrical activation of the ignition.
t_{di}	Time delay of the igniters = time difference between the electrical activation of the igniters and the first pressure increase. Adds to t_v and must be controlled.
t_1	Combustion duration: time difference between the activation of the ignition source and the point with the highest explosion overpressure (P_{ex}).
W_p	Turning point W_p of the ascending branch of the pressure/time curve.
dP/dt	Maximum slope of the tangent at the inflection point W_p .
P_d	Expansion pressure of storage container = $(P_i - P_e) = 0.6$ bar
P_{ex}	Explosion overpressure: the difference between the pressure at ignition time (normal pressure) and the pressure at the culmination point is the maximum explosion overpressure P_{ex} measured in the 20-I-apparatus at nominal fuel concentration.
P_m	Corrected explosion overpressure: Due to cooling and pressure effects caused by the chemical igniters in the 20-I-apparatus, the measured explosion overpressure P_{ex} has to be corrected.

1.4 Pressure course: Evaluation

1.4.1 Correction of the explosion overpressure at $P_{ex} > 5.5$ bar

Due to the less favorable surface to volume ratio, the explosion pressure measured in the 20-I-apparatus is in general slightly lower than the one measured in the 1m³ vessel. This is caused by cooling effects. Comparisons of pressure/time recordings also show that the pressure drop after the explosion is much faster in the 20-I-apparatus. Therefore a correction has to be made according to the following equation:

$$P_m = 0.775 \cdot P_{ex}^{1.15}$$

With this correction, the P_m in the 20-I-apparatus corresponds to that of the 1m³ vessel.

1.4.2 Correction of the explosion overpressure at $P_{ex} < 5.5$ bar

Due to the small volume of the 20-I-apparatus, below 5.5 bar the pressure effect caused by the chemical igniters must be taken into account. A blind test i.e. with $IE = 10'000$ J chemical igniters alone, will give a maximum overpressure of 1 bar. But during a dust explosion with rising P_{ex} the influence of the igniters will be more and more displaced by the pressure effect of the explosion itself. Correction values can be taken from the following equations:

$$P_m = 5.5 \cdot (P_{ex} - P_{ci}) / (5.5 - P_{ci}) \text{ bar}$$

where

$$\begin{aligned} P_{ci} &= \text{pressure due to chemical igniters} \\ &= 1.6 \text{ bar} \cdot IE / 10'000 \end{aligned}$$

For the decision "ignition / no ignition" for LEL (MEC) and LOC with 2 x 1000 J (EN 14034-3.4) and 1 x 2500 J (ASTM), the factor 1.6 agrees well with the measurements.

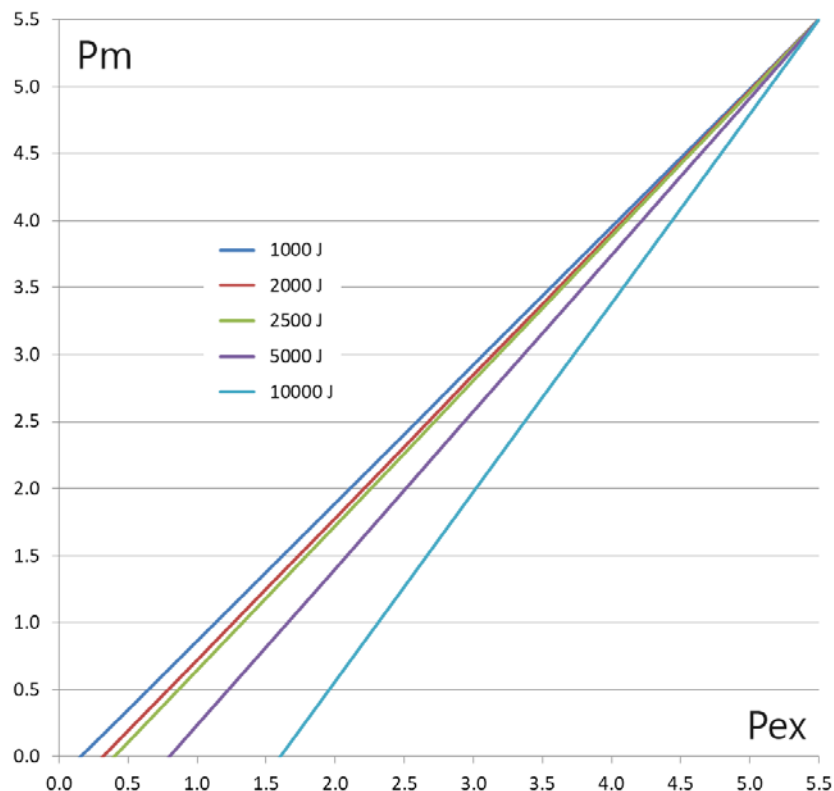

1.5 Influential parameters

1.5.1 Turbulence

The degree of turbulence is mainly a function of the ignition delay time, t_v , i.e. the time between the onset of dust dispersion and the activation of the ignition of the dust/air mixture. It affects in particular the maximum rate of pressure rise, i.e. the K_{max} value. Therefore, for dust testing, the ignition delay time has been standardized:

20-I-apparatus:	$t_v = 60 \text{ ms}$
1m ³ vessel:	$t_v = 0.6 \text{ s}$

Normally, an increase of turbulence ($t_v < 0.6 \text{ s}$ or $t_v < 60 \text{ ms}$) will also increase the explosion violence, and vice versa.

1.5.2 Particle size

Particle size distribution has an important influence on the explosion data. Particle size is characterized by the median M . The median is the 50% value of the particle size distribution curve.

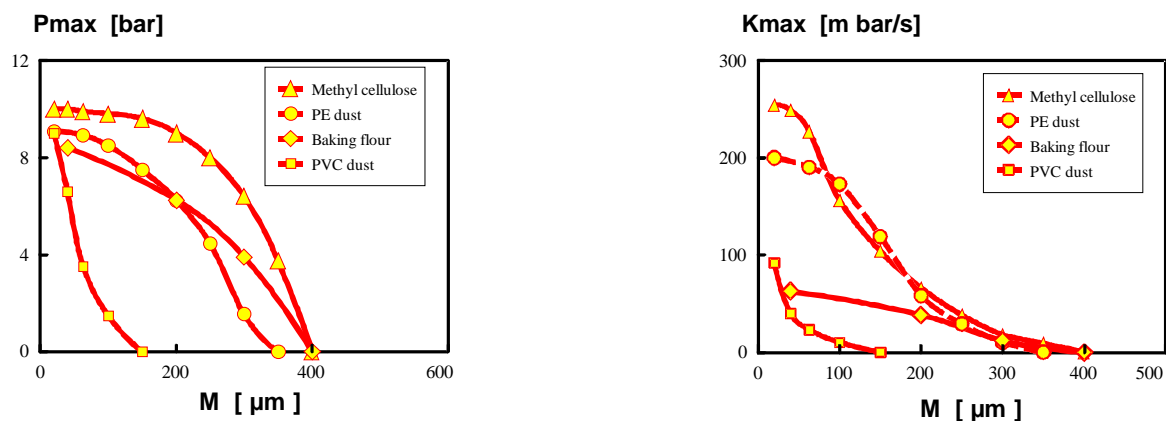

Fig. 1.5.2: Median vs. explosion data

It can be seen from fig. 1.5.2 that finer dusts will react more violently than coarser ones. Therefore, to obtain optimum values for the explosion data, the samples used for testing should have a median $M \leq 63 \mu\text{m}$.

Experience has shown that the dispersion device and the outlet valve may have a grinding effect on the dust being tested, i.e. the size of the dust particles may be reduced by the dispersion process! In cases where this effect is important, its magnitude can be evaluated by taking a dust sample after dispersion (without ignition).

1.5.3 Product humidity

The relative product humidity „H“ i.e. the ratio of water to dry substance, is another influential parameter:

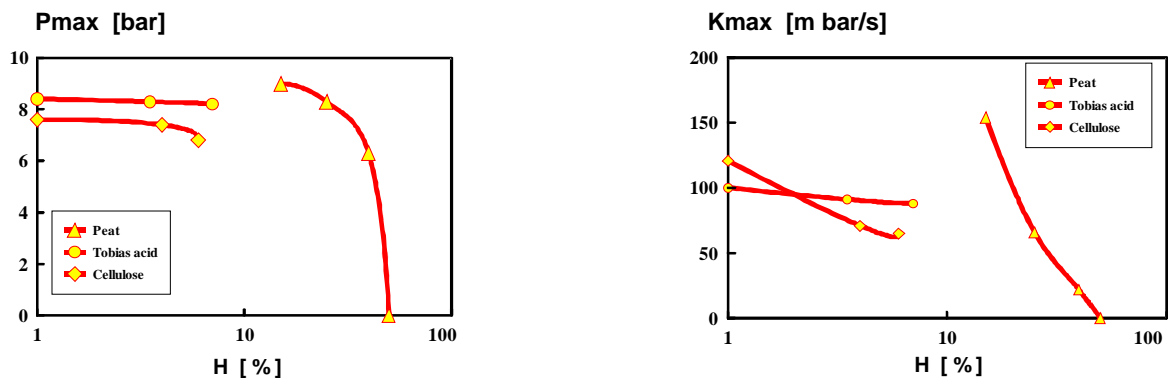

Fig. 1.5.3: Product humidity vs. explosion data

Often the statement can be heard that dusts containing a few % of water can no longer form explosive dust/air mixtures. Fig. 1.5.3 contradicts this assumption. Although comparatively few test results are available, it seems that a product humidity of at least 50% would be required to cause this effect. But fig. 1.5.3 demonstrates that product humidity should be clearly below 10% to avoid an important influence on the explosion data.

1.5.4 Temperature

Temperature is a very important parameter in industrial operations. An increase of temperature will reduce the value of the lower explosion limit. This influence is more pronounced the higher the value is at room temperature. Furthermore, the influence of temperature on the Pmax must be taken into account:

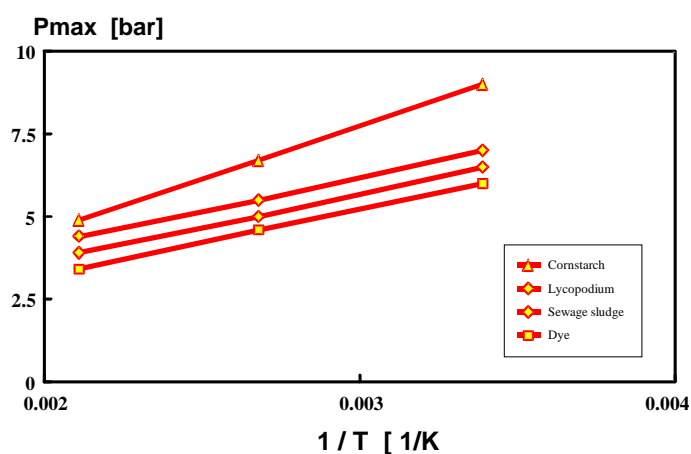

Fig. 1.5.4: Influence of temperature on Pmax

The figure shows a practically linear reduction of the maximum explosion pressure **Pmax** with increasing temperature. This is caused by the reduced oxygen content.

As shown in Fig. 1.5.4, the maximum explosion pressure decreases practically linearly with increasing temperature. The reason for this is the reduced oxygen content. The K_{max} value is also subject to the influence of temperature. In the case of more vigorously reacting dusts, the increase in temperature generally results in a linear decrease, whereas in the case of less vigorously reacting dusts, the K_{max} values increase. In practice, the influence of temperature on the K_{max} value can be neglected.

"Calculate / P_{max} : influence of temperature"

<input checked="" type="radio"/> P_{max} : influence of temperature T	P_{max} at 20°C	8.2	bar
<input type="radio"/> P_{max} : influence of initial pressure P_i	Temperature T	50	°C
<input type="radio"/> K_{max} : influence of initial pressure P_i	P_{max} at T	7.5	bar

1.5.5 Initial pressure

The explosion indices P_{max} and K_{max} are direct proportional to the initial pressure P_i , the pressure in the sphere at the moment of ignition. This relation is linear up to an initial pressure of approx. 3 bar.

"Calculate / P_{max} : influence of initial pressure P_i "

	P_{max} at P_o	8.1	bar
<input type="radio"/> P_{max} : influence of temperature T	P_o	990	mbar,abs
<input checked="" type="radio"/> P_{max} : influence of initial pressure P_i	P_i	1013	mbar,abs
<input type="radio"/> K_{max} : influence of initial pressure P_i	P_{max} at P_i	8.2	bar

"Calculate / K_{max} : influence of initial pressure P_i "

	K_{max} at P_o	252	m · bar/s
<input type="radio"/> P_{max} : influence of temperature T	P_o	990	mbar,abs
<input type="radio"/> P_{max} : influence of initial pressure P_i	P_i	1013	mbar,abs
<input checked="" type="radio"/> K_{max} : influence of initial pressure P_i	K_{max} at P_i	257.8	m · bar/s

1.6 Mode of ignition and ignition energy

From a large number of test results obtained in the 1m³ vessel and in the 20-I-apparatus for the minimum ignition energy, it appears that dusts can be ranged into 2 groups with regard to the influence of the mode of ignition and the ignition energy on the explosion data.

1.6.1 Energy independent dusts

Fig. 1.6.1 shows that the measured explosion data are, within the accuracy of measurements, independent of the mode of ignition and the ignition energy (chemical igniters for IE = 250 ... 10,000 J, condenser discharge for IE > MIE).

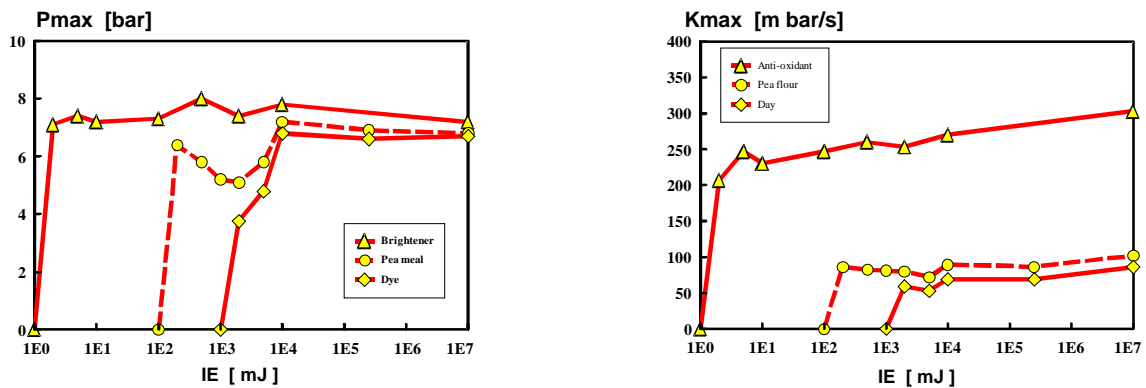

Fig. 1.6.1: definition of energy - independent dusts

From these findings it can be concluded that with these "energy independent dusts" the nature of the ignition source is not important. Weak condenser discharges or strong chemical igniters, such as specified for dust testing, give the same results.

In general, such dusts have a minimum ignition energy of less than 1 J.

1.6.2 Energy dependent dusts

With this group of dusts, a decrease of the ignition energy will cause a linear reduction of the Kmax value.

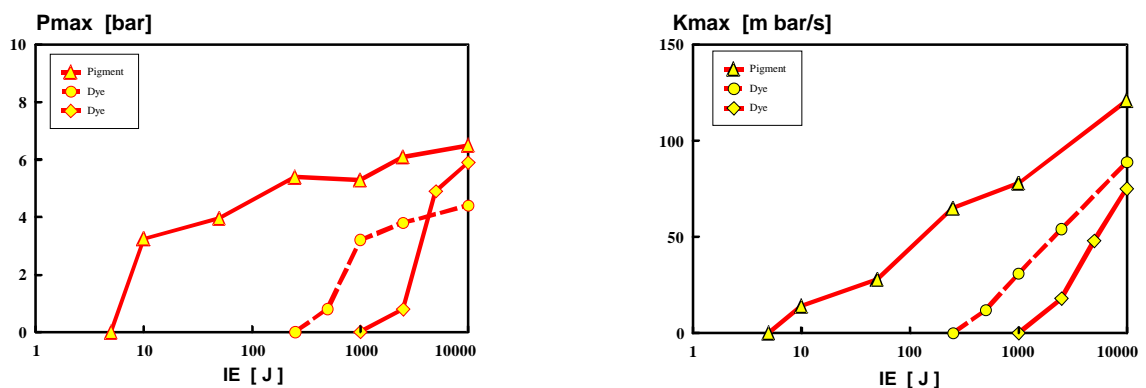

Fig. 1.6.2: Definition of energy **dependent** dusts

The explosion pressure is practically not subject to this influence; only with very few dusts a tendency to decrease can be observed.

In general, dusts in this group have a minimum ignition energy of more than 1 J.

1.6.3 Chemical igniters

Explosion indices must be determined using an ignition source of sufficient energy. For the time being, there is only one mode of ignition for reliable determination of explosion indices (P_{max} , K_{max}) in industrial practice:

2 chemical igniters of 5000 J each, with a total energy of **E = 10'000 J**

For the determination of lower explosible limit LEL and the limiting oxygen concentration LOC:

EN 14034-3, 4: 2 igniters with **1000 J** each and a total energy of **E = 2000 J**

ASTM E1515, E2931: 1 igniter with **E = 2500 J** or with **E = 5000 J**

It is emphasized that the application of this ignition source for dust testing is of dominating importance, not only to ensure that test results can be compared among different laboratories, but also in order to provide a reliable base for the design of technical explosion safeguards.



For the safe handling of the chemical igniters wearing of safety glasses is mandatory.



If powder is visible on the surface of the igniters as well as in the baggage of the igniters itself an ignition risk due to static electricity exists. Therefore buildup of static electricity must be avoided (earthing of the operator etc.).



The chemical igniters should be stored in a safe place in a cool and dry atmosphere. In addition national guide-lines should be obeyed.

Manufacturer:

Fr. Sobbe GmbH
Beylingstr 59
D-44329 Dortmund
Germany
Tel: +49 231 230 560
info@sobbe-zuender.de
www.sobbe-zuender.de

Manufacturer:

Simex Control s.r.o.
Ul. 4. kvetna 175
Vsetín 755 01 CZ
Czech republic
Tel: +42 0571 498 711
sale@simexcontrol.cz

Distributor for USA and Canada:

Cesana Corporation
P.O. Box 182
Verona, NY 13478
U.S.A.
Tel: +1 315 337 9181
office@cesanacorp.com

1.6.4 Condenser discharge

It must be pointed out that with a condenser discharge spark as an ignition source, the same course of pressure of a dust explosion is obtained as with chemical igniters, provided that the energy of the condenser discharge is above the minimum ignition energy.

Exceptions are, of course, encountered with dusts which are not readily ignitable and therefore have energy-dependent K_{max} values.

1.6.5 Permanent spark

If instead of chemical igniters a permanent spark with an approx. energy of $IE = 10 \text{ J}$ is used as an ignition source. Measured K_{max} values can be up to 60% lower than the values obtained with the two other ignition sources already mentioned.

Thus, the permanent spark can underestimate to a considerable degree the effective course of the explosion and must not be used for the determination of the explosion data of combustible dusts.

1.6.6 Glowing wire coil

Numerous comparative tests with chemical igniters and glowing wire coil have shown no correlation.

Most dusts tested with the glowing wire coil have either not been identified as explosive dusts or the explosion violence was underestimated. Therefore, this ignition source is not suitable for an unambiguous identification of explosive dusts nor a reliable determination of dust explosion indices.

1.7 20-I-sphere

The test chamber is a hollow sphere made of stainless steel, with a volume of 20 liters. A water jacket serves to dissipate the heat of explosions or to maintain thermostatically controlled test temperatures.

For testing, the dust is dispersed into the sphere from a pressurized storage chamber via the outlet valve and a nozzle. The outlet valve is pneumatically opened and closed by means of an auxiliary piston. The valves for the compressed air are activated electrically.

The ignition source is located in the center of the sphere. On the measuring flange two "Kistler" piezoelectric pressure sensors are installed. The second flange can be used for additional measuring elements or for the installation of a sight glass.

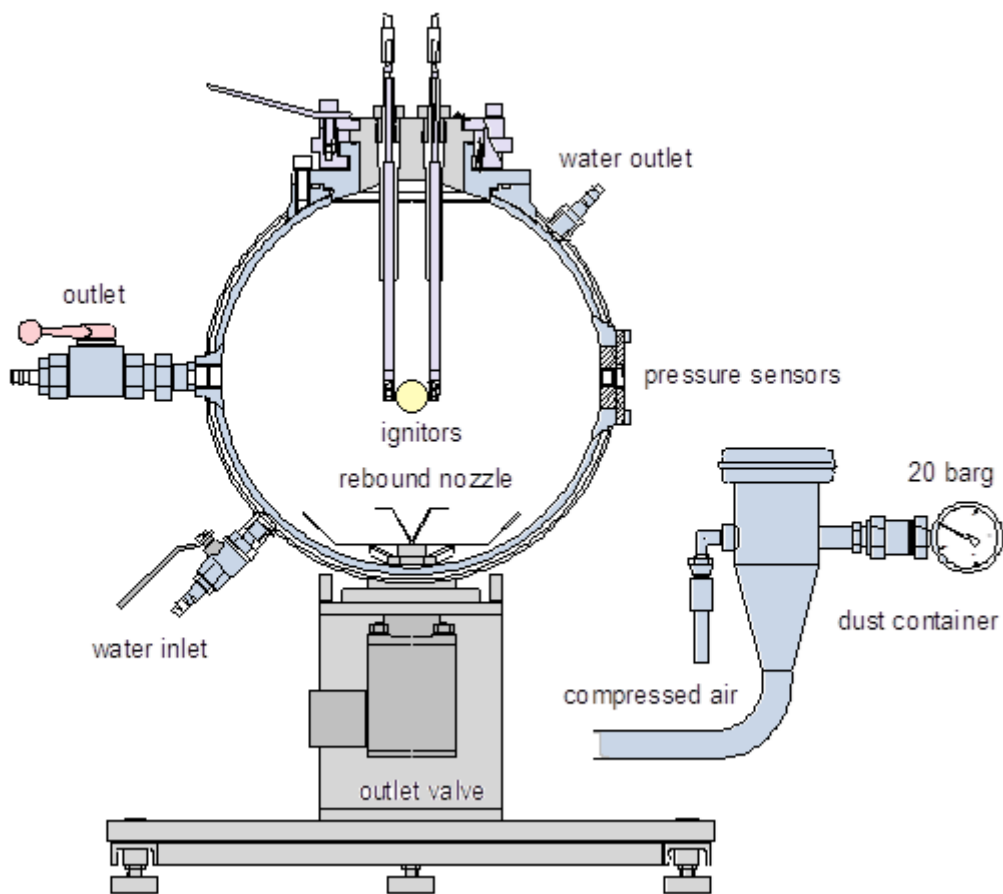

1.8 Nomenclature

(dP/dt)_m	greatest rate of pressure rise at any desired fuel concentration
(dP/dt)_{max}	maximum rate of pressure rise at optimum fuel concentration
IE	ignition energy
K	product specific constant
K_{max}	maximum value of the explosion index K
LEL	lower explosion limit
LOC	limiting oxygen concentration
M	median
MIE	minimum ignition energy at the most easily ignitable fuel concentration
P_d	pressure difference
P_{ex}	greatest explosion overpressure at any desired fuel concentration, measured in the 20-I-apparatus
P_m	corrected greatest explosion overpressure at any desired fuel concentration, measured in the 20-I-apparatus according to the ISO-Standard
P_{max}	maximum value of the explosion index P _m at optimum fuel concentration, measured in the 20-I-apparatus according to the ISO-Standard
P_i	initial pressure
P_z	dispersion pressure
St	dust explosion class
t₁	combustion time
t₂	induction time
t_d	time delay of the outlet valve
t_{di}	Time delay of the igniters
t_v	ignition delay time
UEL	upper explosion limit

2. Software

Prerequisite: Operating system „Microsoft-Windows“ 7...11 (32/64-bit)

Installation: Please run the following Windows setup file: [KSEP80_setup.exe](#)

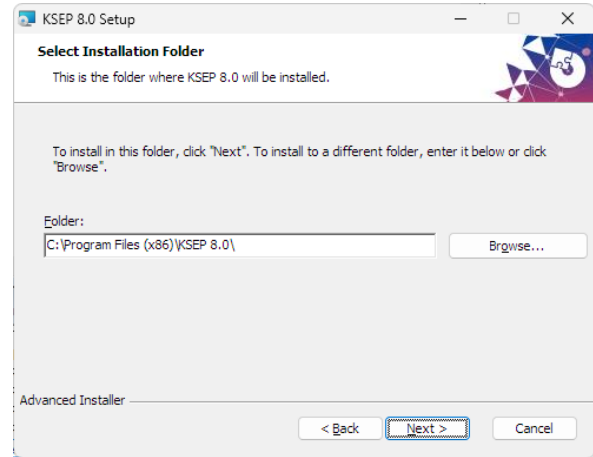

Start the KSEP 8.0 software and follow the instructions:

Setup 1: Language

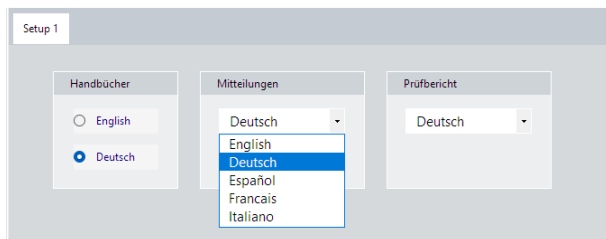

The program is always in English.

In addition to the predefined languages for messages to the operator and the test report, you can create your own translation files.

See: [7.3 Translations](#)

Setup 2: Company

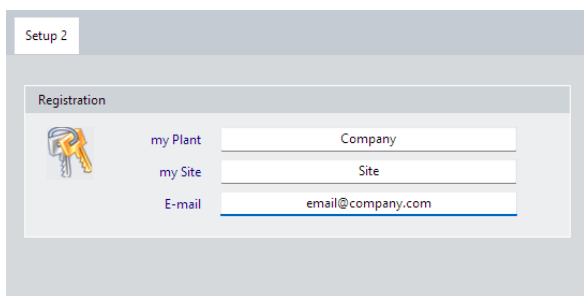

my Plant = Company name

my Site = Test laboratory

for new files and the test report

E-Mail just for info

Setup 3: Administrator

Setup 3

1. Administrator

Signature e.g. John Smith

* Username e.g. JS

* Password

* Password confirmation

KSEP-filename starts with ...

The 1st administrator is defined here.
Further users can be added in "Users".

Signature = Full name.

Will be inserted into the reports like this.

Username = a useful short form.

KSEP-filename starts with ...

Automatically created file names begin with this, followed by the date the file was opened.

The letter following it distinguishes files created on the same day.

Example: Lab_230224A.K20 These automatically created file names are only a suggestion.

Of course, you can enter your own file name (e.g. order number).

The extension of the file name is always "K20" or "1m3" and is added automatically.

Setup 4: Apparatus

Setup 4

1. Equipment

1.1 Vessel Serial no

1.2 Nozzle

1.3 Igniters

1.4 Altitude above sea level

2. Piezoelectric pressure sensors

2.1 Sensor A Sensitivity [pC/bar]

2.2 Sensor B Sensitivity [pC/bar]

Altitude above sea level =

Height above sea level from your laboratory.

In the footer of the program, the current static pressure and the calculated value related to sea level are displayed. In comparison with the current meteo data, this value should agree:

(± 10 hPa = $\pm 1.0\%$)

Pressure sensors

The sensitivity of the transducers can be found in the corresponding calibration data.

(Range = 0...5bar or 0...20bar)

The KSEP 333 unit uses piezoelectric pressure transducers to measure the dynamic pressure curve.

A quartz crystal is deformed by pressure. An electric charge is generated on its surface, proportional to the pressure difference. This is converted in the charge amplifier into a digital signal.

Setup 5: Equipment

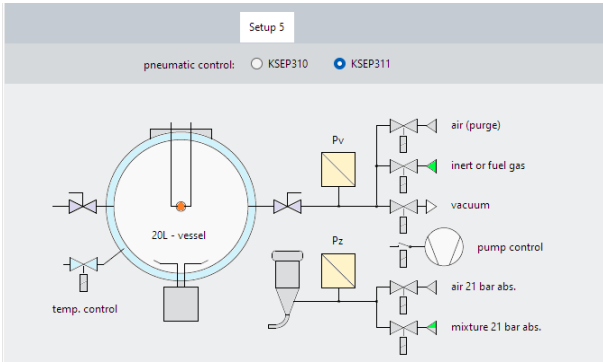

20L-sphere + KSEP333 + KSEP311

Pressure Pv, Pz: absolute, digital
Evacuation: automatic
Partial-pressure method: automatic (LOC, Hybrid mixture, Gas)
Vessel temperature control

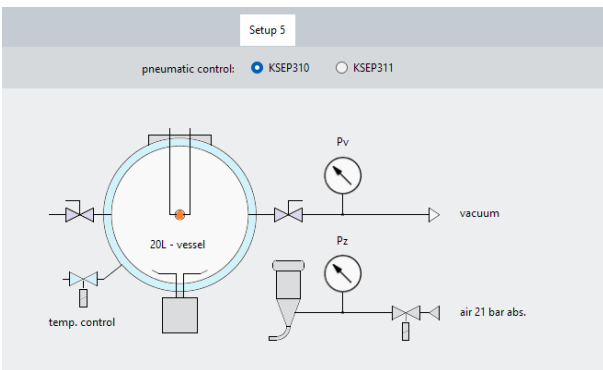

20L-sphere + KSEP333 + KSEP310

Replacement for old KSEP330...KSEP332
Pressure Pv, Pz: relative, analogue
Vessel temperature control

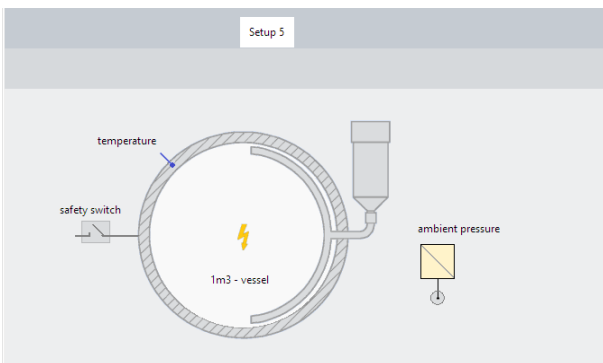

1m3-vessel + KSEP333

Measurement and correction of:
Ambient pressure (absolute, digital)
and vessel temperature

Setup 6

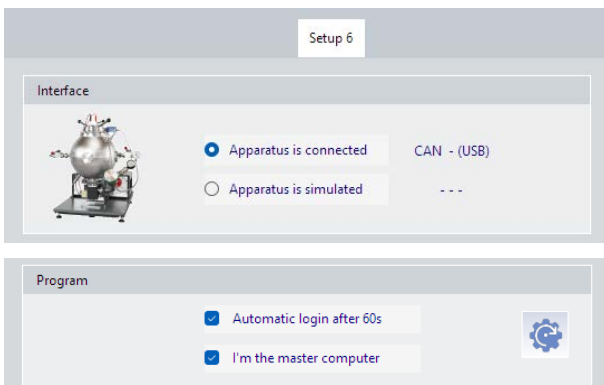

Interface

The equipment is connected
or is simulated.

Program

Automatic login ... automatic program start
Master ... One is the primary PC.

CAN-Driver

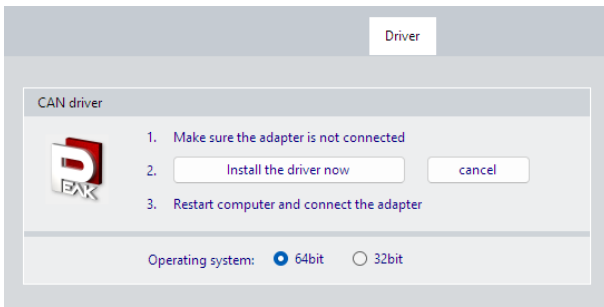

For the installation you need administrator rights. For the later use however no special rights are necessary.

Please do not use USB extension cables between CAN-USB adapter and PC. This does not comply with the USB standard and can lead to malfunctions.

Installation

- a) Do not connect the CAN adapter.
- b) Install the Peak driver.
- c) Connect CAN adapter to USB port.
- d) Windows notifies about new hardware.
- e) Restart the KSEP333 program.

Info

There is a red LED on the CAN-USB adapter:
 Constantly lit: connected to Windows
 Slow blinking: connected to KSEP333
 Fast blinking: data is being transferred

CAN-ID

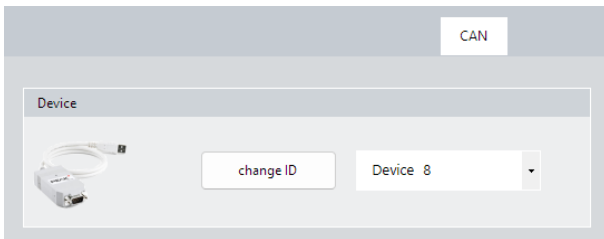

If several CAN adapters are connected to your PC, they must be uniquely identified.

For a new adapter, this number is usually 255 (0xFF). You can change this easily: [change ID](#)

Users

Users					
no	username	signature	authorization	enabled	status
1	JS	John Smith	Administrator	✓	active
2	SE	Hanks	Service	✓	new
3	SU	Cruise	Supervisor	✓	new
4	OP1	Laurel	Operator	✓	new
5	OP2	Hardy	Operator	✓	new
6					
7					
8					
9					

The 1st administrator is defined at Setup 3. Further users can be added here:

- "Administrator" for the management of users.
- "Service" for calibration and maintenance.
- "Supervisor" for process monitoring.
- "Operator" for all other users.

Rights

Rights					
no	can do ...	Administrator	Service	Supervisor	Operator
1	New tests	✓	✓	✓	✓
2	Filemanager (new, save)	✓	✓	✓	✓
3	Table modification	✓	✓	✓	✓
4	Test conditions	✓	✓	✓	
5	Software Update	✓	✓		
6	System - Settings	✓			

The rights of the 4 user groups can be defined here by the administrator.

3. Operation



After starting the program
Select the desired user.
See: [2.2 PC software users](#)

New users must first define their own password.

username	signature	authorization	status
CC	Ch. Cesana	Administrator	active
SE	Clint Eastwood	Service	active
SU	Terence Hill	Supervisor	new
OP	Bud Spencer	Operator	new

	Password <input type="text"/>	Login
--	-------------------------------	-------

3.1 Info

The screenshot shows the KSEP 8.0 software interface. The main window displays product information for 'Niacin (CaRo24)' and various test parameters. The status bar at the bottom contains several indicators labeled 1 through 9.

parameter	value	unit	tolerance	Series 1	Series 2	Series 3
Pmax	8.3	bar	± 10%	-0.1%	-1.5%	1.6%
(dP/dt)max	890	bar/s	± 10%	-2.6%	5.3%	-2.7%
Kmax	242	m-bar/s	± 10%	t1 min	27	ms

procedures	tests
Test check	0
Dust: Pmax, Kmax	22
Dust: Lower explosion limit	11
Dust: Limiting oxygen concentration	27
Dust: Explosibility	0
Hybrid: Pmax, Kmax	0

CC	Administrator	Master	20L + KSEP311	CAN 3	1022 mbar	1.0 bar	23°C	2502
----	---------------	--------	---------------	-------	-----------	---------	------	------

Status bar

1. The current user
2. Authorization of the user
3. Priority
4. Test equipment
5. CAN interface
6. Pressure in the sphere
7. Pressure in dust storage
8. Vessel temperature
9. Version, year, week

Remote control

The function of the remote control depends on the position of the two ball valves. The sphere and the safety switch must be closed. The on-screen buttons can be used as an alternative to the remote control.

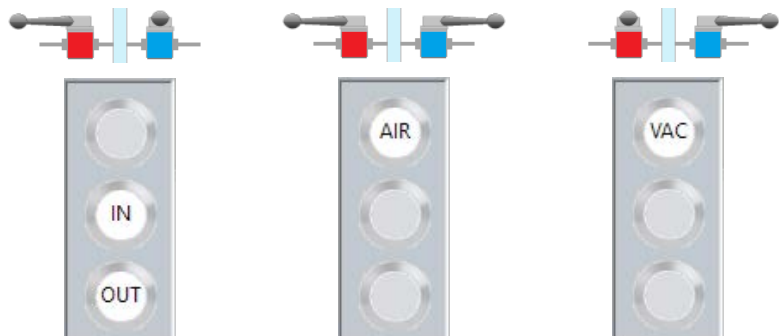

3.2 KSEP-Files



New product, new file

When starting with a new product, a new file is opened. The file name is either generated automatically by the program (**A**) or entered by you (**B**):

- A:** Automatically generated file names always start with the identity you defined (See: [2.3 PC-Software](#)) followed by the date. The following letter distinguishes files that were created on the same day.

Example 1: Lab_230224A.K20

Example 2: Lab_230224B.K20 (created on the same day as example 1)

- B:** Example 3: myProduct.K20 (max. length of the file name = 126 characters)



Existing product, open file

A directory of KSEP files with indication of the product is displayed. For ascending or descending sorting click on the corresponding field (filename, date, product).

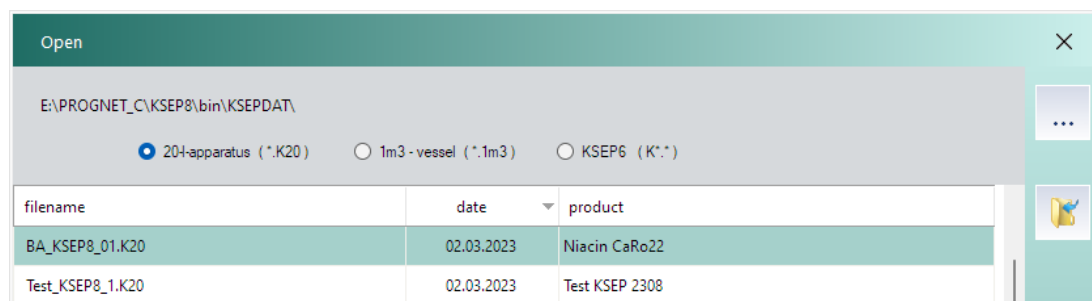

Save file as ...

All data is always saved **automatically**. If necessary, you can save the entire recording under a new file name in a separate file.



Copy files

An easy to use file manager for copying KSEP files is built in. Only KSEP files are displayed.

Windows-style file dialog

File selection in Windows style or with product display.

3.2.1 Access rights



In the laboratory, the software must be suitable for the equipment. In the office, we recommend the KSEP 8.0 software, as it can read all older files, is much easier to use and more flexible in the test report.

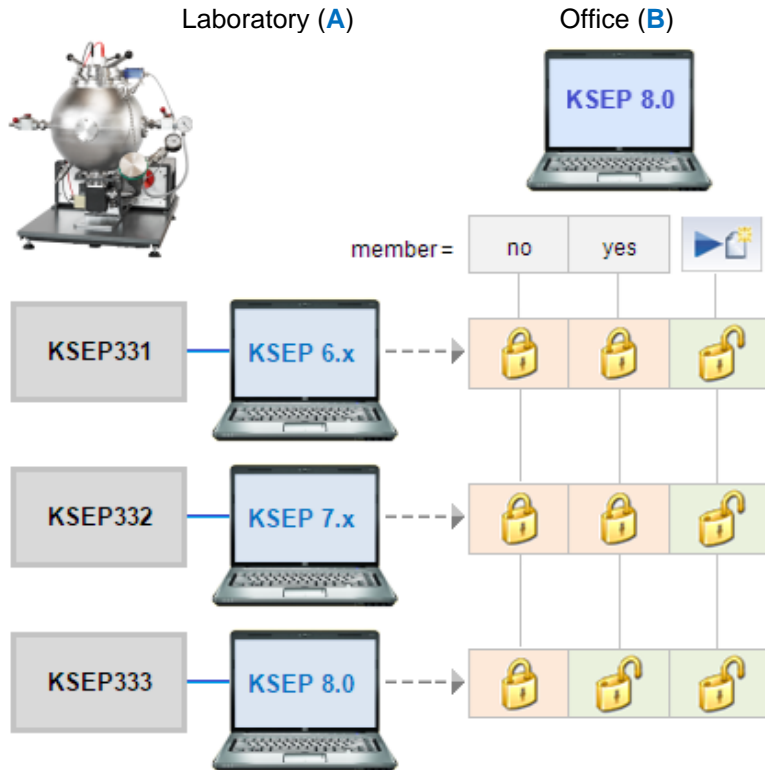

When transferring files to other computers, e.g. from the laboratory (A) to the office (B), the users must be taken into account. The user (B) must be a **member** in user list of the laboratory (A). Otherwise the data must be imported.



locked

All manipulation of the data is blocked, except for viewing and printing.



freely accessible

You can edit the tables and add comments.



KSEP6 - files do not yet have user administration and the file format is different. Therefore, the KSEP6 file must be saved in KSEP8 format for manipulations.

A new file name is generated: e.g. K030618A.SIB becomes K030618A_i6.K20

Locked **KSEP7**- or **KSEP8**- files must be imported for free access.

A new file name is generated: e.g. CaRo24.K20 becomes CaRo24_i7.K20

For the user management, the import of data is registered in the audit:



no	date	time	cause	event	username	signature
95	27.03.2025	10:19	OP1	KSEP data imported	JS	John Smith
					OP1	my Operator 1

3.3 Test procedure

3.3.1 Preparation

Static pressure measurement

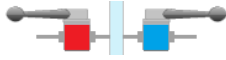

Both ball valves are open. There is ambient pressure in the sphere.

The correct pressure display is easy to check:

The altitude above sea level of your equipment is entered in "Setup". The current static pressure and the calculated value in relation to sea level are displayed in the footer of the program. This value must match the current meteorological data ($\pm 10 \text{ hPa} = \pm 1.0\%$).

Move the mouse pointer onto the display of the static sphere pressure:

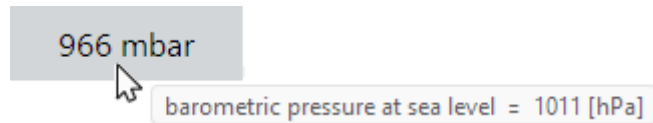

Tightness of the dust storage container

After every major cleaning, the tightness of the dust reservoir and sphere must be checked as follows:



1. Fill the dust reservoir to 20 bar with air. Button „**IN**“.
2. Does the pressure remain constant?
If it drops continuously, the **dust storage is leaking**.
Possible cause: Dirt on the outlet valve.
3. Empty the dust storage with the „**OUT**“ button.
(on-screen or remote-control buttons)

Tightness of the sphere



1. Evacuate the sphere to 400 mbar. Button „**VAC**“.
(Toggle function: 1 x press = ON, press again = OFF)
2. The pressure remains constant → everything OK
The pressure increases continuously → 3.
(on-screen or remote-control buttons)
3. Close the right-hand ball valve.
4. The pressure now remains constant → **Sphere is leaking**.
5. The pressure increases continuously → **Vacuum filter leaking?**
→ **Connections leaking?**

3.3.2 Test check

The explosion characteristics Pmax and Kmax are influenced proportionally by the initial pressure Pi.
According to standards: **Pi = 1013 mbar = Normal pressure**

1. Choice of test procedure:

Test procedure **without dust**
and **without igniters**

procedures	tests
Test check	0
Dust: Pmax, Kmax	22
Dust: Lower explosion limit	11
Dust: Limiting oxygen concentration	27

2. Automatic preparation:

automatic preparation

3. Start preparation:

Evacuation of the sphere and filling of the dust container take place in steps. If the set values are not reached after 1 min, the test must be aborted.

- Sphere leaking?
- Compressed air < 22 bar, absolute?

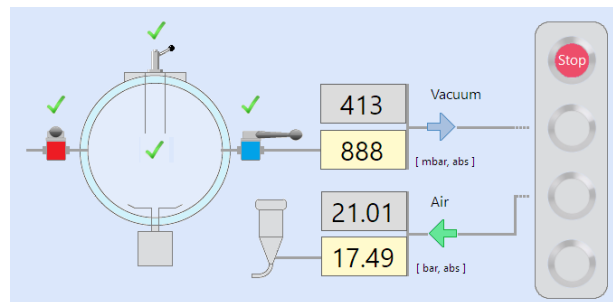

4. Start test:

Close the ball valve and start the test by pressing the OK button on the screen or on the remote control.

Do not wait too long. The pressures may change due to leaks.

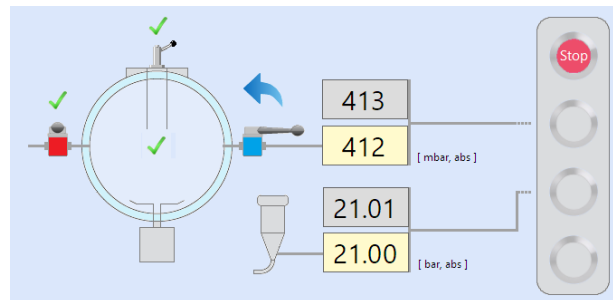

5. Check initial pressure Pi:

A theoretical initial pressure is calculated from the measured pressures of the preparation:

check: Initial pressure Pi = 1013 mbar ?

After opening the right-hand ball valve, the effective initial pressure Pi is displayed.

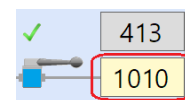
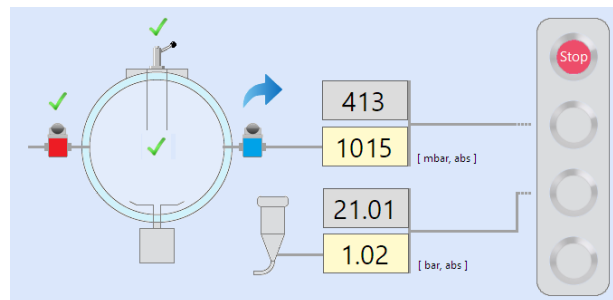

1013mbar ±2% = 993 ... 1033mbar

Permissible values for the calculated and effective initial pressure are:

If there are major deviations **leakage** is suspected.



If the initial pressure **Pi** is correct, the calibration chain applies:
Meteodata → Ambient pressure **Pv** → test check → Dispersion pressure **Pz**

6. Display of pressure curve

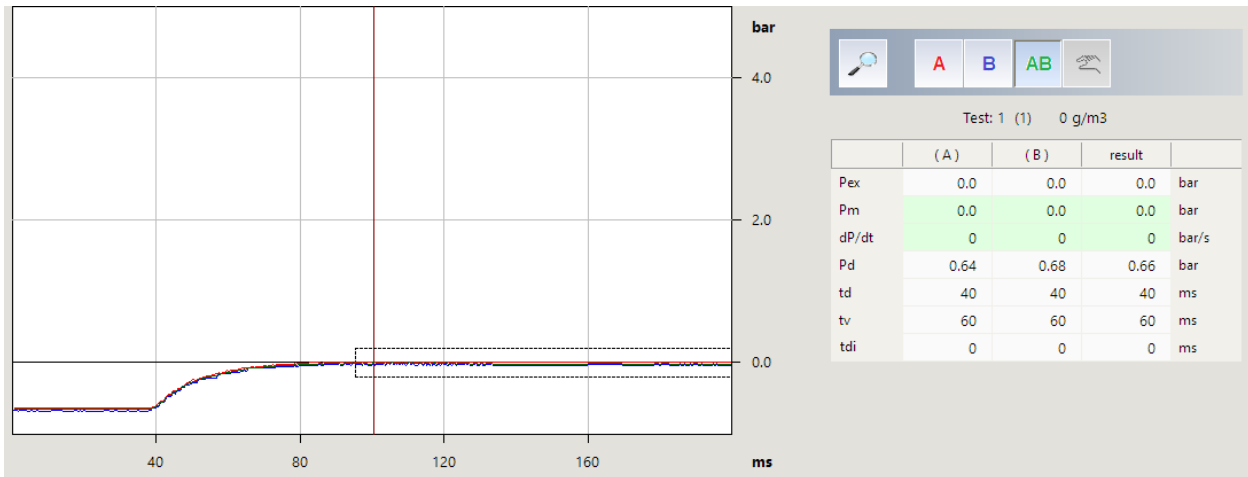

Use the mouse to drag a window around the section to be enlarged. Press this button to display the section.



Switch to the overview display.



In addition to the explosion characteristics, the results of the preparation can be displayed. The absolute initial pressure P_i is calculated from the measured values of P_v and P_z.

dP/dt	Test: 28 (1) 0 [g/m3]		
	setpoint	effective	FS [%]
P _v Vakuum [mbar]	413	412	-0.1
P _z Luft [bar]	21.01	21.01	0.0
P _i berechnet* [mbar]	1013	1012*	



Error messages: All evaluation is done automatically. The following control variables are monitored and displayed in red if the values are unacceptable:

- P_d** Expansion pressure of the dust storage:
The nominal value is **0.6bar** (permissible are: **0.55...0.75bar**).
Check the thickness or hardness of the silicone protective layer on the Kistler pressure transducers.
- t_d** The time delay of the outlet valve is not within the permitted range of **30...50ms**.
The outlet valve may be dirty or the rebound nozzle may be clogged.

3.3.3 Dust: Pmax, Kmax

Test Conditions

Procedure		= Dust: Pmax, Kmax
Ignition source		= Chemical igniters
Ignition energy	IE	= 2 x 5 kJ
Ignition delay time	tv	= 60 ms

Test Method

In a first test series, the maximum explosion overpressure and the maximum rate of pressure rise are determined over a wide range of concentrations. Starting with a low dust concentration of 60g/m³ (1.2g / 20-l), the concentration is increased in steps, until the maximum values for the explosion pressure and the rate of pressure rise have clearly been determined. The following steps must be used:

60; 125; 250; 500; 750; 1000; 1250; 1500 g/m³

After the first test series, the concentration range close to the observed maxima (Pmax, (dP/dt)max) is twice checked, i.e. the tests are repeated at the optimum concentration, the next higher and the next lower concentration. An example:

(Assuming, the maxima of Pm and (dP/dt) are at 250 resp. 500 g/m³)

- | | | | | | | |
|------------|-----|------|------|------|------|-----------------------|
| 1. Series: | 60, | 125, | 250, | 500, | 750, | 1000 g/m ³ |
| 2. Series: | | 125, | 250, | 500, | 750 | |
| 3. Series: | | 125, | 250, | 500, | 750 | |

Assembly of the igniters

Two chemical igniters (Z) with 5kJ energy each are mounted on the electrode rods (S) as shown in the picture. I.e. the igniters fire horizontally and in opposite directions.



Sobbe igniters are electrically connected in **parallel**.

Simex igniters are already pre-wired (series connection).



The ignition delay time for Simex igniters is on average 5ms shorter than for Sobbe.

There is a possibility that the outlet valve is not yet fully closed at the ignition time and thus "Backfire" into the dust reservoir can occur. For this reason, the ignition timing of Simex igniters is automatically corrected by 5ms.

See: [2. Software / Setup 4: Apparatus](#)

Procedure

Recommended:

automatic cleaning

automatic preparation

1. Settings

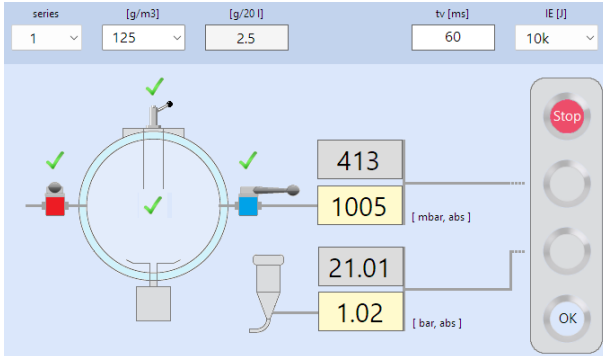

Set test parameters and confirm with OK.

2. Start test

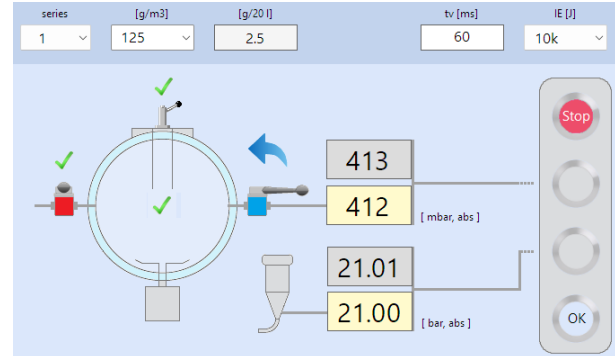

After completing the automatic preparation, start the test.

Button on the screen or on the remote control.

3. Rinsing the sphere:

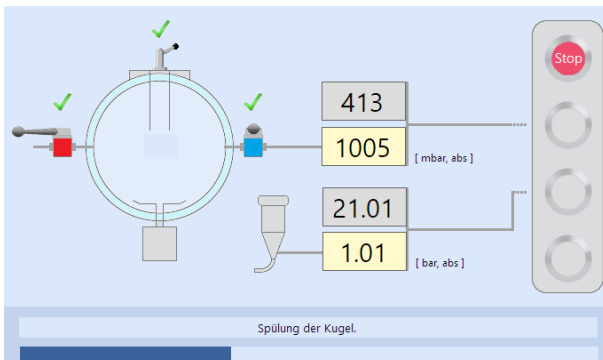

4. Rinsing the right ball valve:

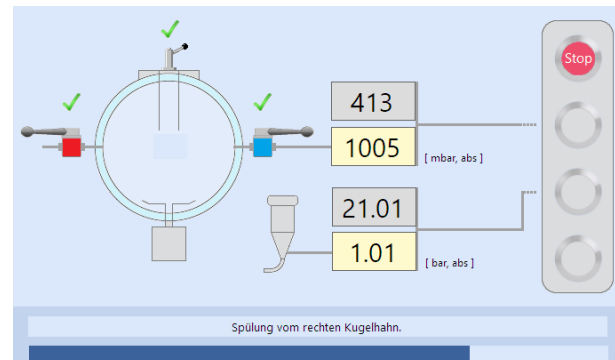

5. After the test:

- Open sphere and remove the combustion residues with a vacuum cleaner.
- Remove spent igniters and clean electrode rods.
- Clean the rebound nozzle: All bores must be free.
- Remove the residues in the dust storage container with a vacuum cleaner.

Pressure curve

After the automatic test procedure, the pressure curve of channel 1 (red), channel 2 (blue) and their mean value (green) is displayed. The vertical line defines the time of ignition. The cobalt blue color shows the tangent of the maximum pressure increase over time, the corresponding inflection point and the cross for the maximum explosion pressure P_{ex} .

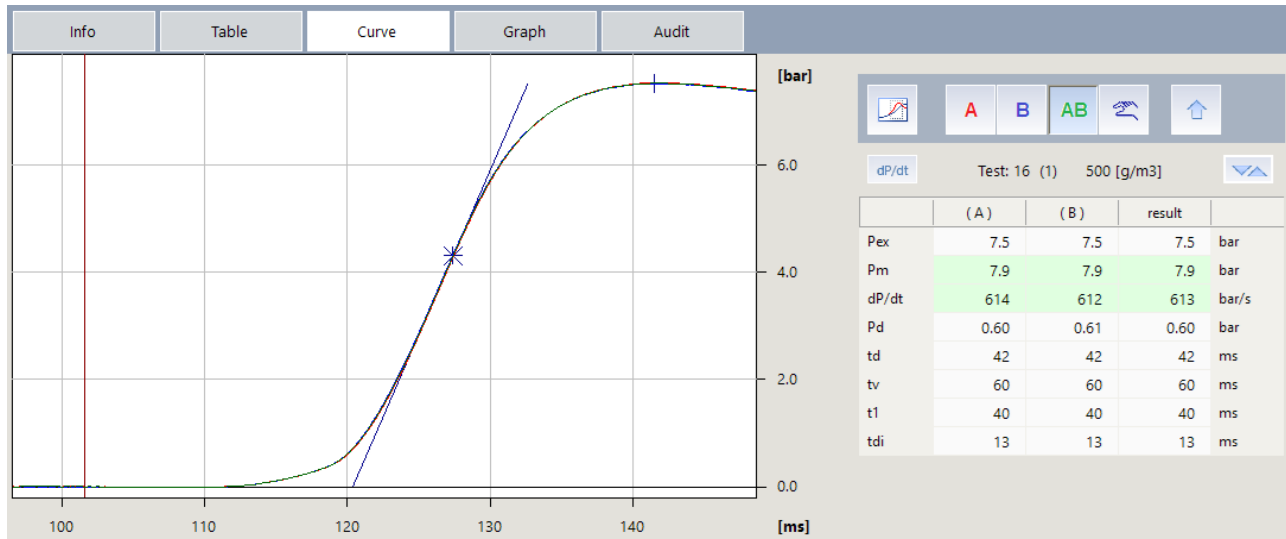

Switch to the overview display.



Use the mouse to drag a window around the section to be enlarged.
Press this button to display the section.



The average value from both measuring channels is evaluated and displayed (green line).
Default setting.



Only channel A is evaluated.
Useful if channel B is faulty.



Only channel B is evaluated.
Useful if channel A is faulty.

Error messages:

- P_{ex}** A difference of more than **0.3bar** has occurred between the two pressure electrodes.
- P_m** Pressure transducer interchanged?
- dP/dt** Rates of pressure rise are different (**> 10%**).
- P_d** Dust storage expansion pressure: Typical = 0.6bar (permissible are: **0.55...0,75bar**).
- t_d** The time delay of the outlet valve (permissible are: **30...50ms**)
- t_v** The measured ignition delay time does not correspond to the settings (**$\pm 5ms$**)
- t_{di}** Time delay of the igniters is too large. See: **3.8 Test-Settings**

Manual evaluation

If a $(dP/dt)_m$ of less than 150 bar/s is obtained, it is possible that the rate of pressure rise of the chemical igniters is higher than that of the fuel explosion. It is therefore necessary to compare this explosion pressure curve with the pressure curve caused by the chemical igniters alone and under otherwise identical conditions. Typical values for chemical igniters of 10 kJ are approx. 100 bar/s. It can be assumed that the pressure rise caused by the chemical igniters is terminated after 50 ms. (Thus the tangent may only be drawn at least 50 ms after ignition).

The KSEP 333 automatically compensates for this effect. Of course this simple rule of thumb cannot cover all practical cases, thus a manual evaluation has to be done from time to time:



Observe how and where the computer sets the tangent after an explosion test. Weak explosions or oscillations superimposed on the pressure course may lead to wrong results. If you do not agree, it's best to do a manual evaluation.

Pressure rise dP/dt

For the decision "ignition / no ignition" for LEL (MEC) and LOC, the representation of the rate of pressure rise dP/dt can be useful (see ASTM standards) and helps to differentiate between "igniter" and "dust explosion".

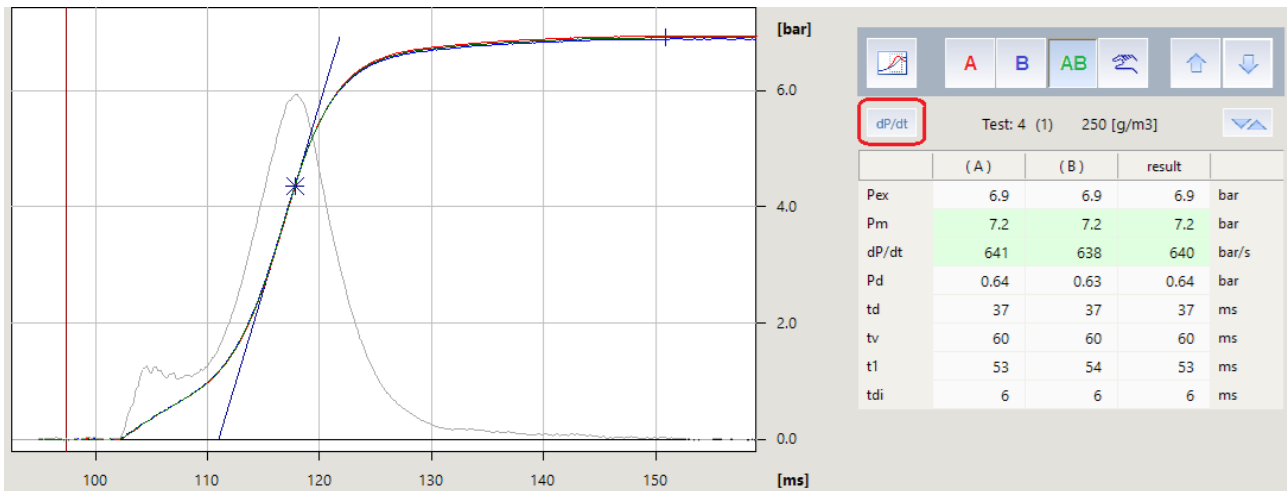

Preparation



In addition to the explosion characteristics, the results of the preparation can be displayed. The absolute initial pressure P_i is calculated from the measured values of P_v and P_z .

	setpoint	effective	FS [%]
Pv vacuum [mbar]	413	410	-0.3
Pz air [bar]	21.01	21.07	0.3
Pi calculated* [mbar]	1013	1012*	

3.4 Table

Separated by procedures, all tests are displayed and processed numerically:

curve	ok	test	series	conc.	Pm	dP/dt	tv	tdi	IE	Tu	comment
▶	✓	13	1	60	0.33	29	60	8	10kJ	24°	
▶	✓	14	1	125	4.7	173	60	8	10kJ	24°	
▶	✓	15	1	250	6.8	546	60	8	10kJ	26°	
▶	✓	16	1	500	8.3	673	60	8	10kJ	27°	
▶	✓	17	1	750	8.2	732	60	8	10kJ	28°	
▶	✓	18	1	1000	8.1	867	60	8	10kJ	29°	
▶	✓	19	1	1250	7.6	750	60	7	10kJ	29°	
▶	✓	20	1	1500	7.0	655	60	8	10kJ	28°	
▶	✓	21	2	125	5.6	278	60	8	10kJ	24°	
▶	✓	22	2	250	7.3	568	60	7	10kJ	25°	
▶	✓	23	2	500	8.1	839	60	6	10kJ	27°	
▶	✓	24	2	750	8.2	938	60	7	10kJ	28°	
▶	✓	25	2	1000	7.7	840	60	8	10kJ	28°	
▶	✓	26	2	1250	7.5	738	60	7	10kJ	28°	
▶	✓	27	3	125	5.7	273	60	7	10kJ	24°	

Pmax	8.3	bar	± 10%	Series 1:	-0.1%	2:	-1.5%	3:	1.6%
(dP/dt)max	890	bar/s	± 10%	Series 1:	-2.6%	2:	5.3%	3:	-2.7%
Kmax	242	m-bar/s	± 10%	t1 min	27	ms			

procedures	tests
Test check	1
Dust: Pmax, Kmax	22
Dust: Lower explosion limit	11
Dust: Limiting oxygen concentration	27
Dust: Explosibility	0
Hybrid: Pmax, Kmax	0

Symbols in the table:

- Maximum value (of any series), light green
- this value is faulty, light red
- this test is valid and will be evaluated (change by clicking on this field)
- the pressure curve is stored
- selected pressure curve

Calculation of the explosion indices:

The explosion indices Pmax and (dP/dt)max are defined as the mean values of the maximum values of each series (total **3 series**).
Subsequently, the explosion index Kmax is calculated from the above (dP/dt)max.

$$P_m [\text{series } n] = \text{maximum value of each series}$$

$$P_{\max} = (P_m [\text{series } 1] + P_m [\text{series } 2] + P_m [\text{series } 3]) / 3$$

$$(dP/dt)_m [\text{series } n] = \text{maximum value of each series}$$

$$(dP/dt)_{\max} = (dP/dt [\text{series } 1] + dP/dt [\text{series } 2] + dP/dt [\text{series } 3]) / 3$$

$$K_{\max} = 0.27144 \times (dP/dt)_{\max}$$

$$\sqrt[3]{1/3} = 0.02^{1/3} = 0.27144$$

3.5 Graph

The individual values (squares), the mean values (crosses) and for "Pm" or "dP/dt" the mean of the maxima (star) are displayed.

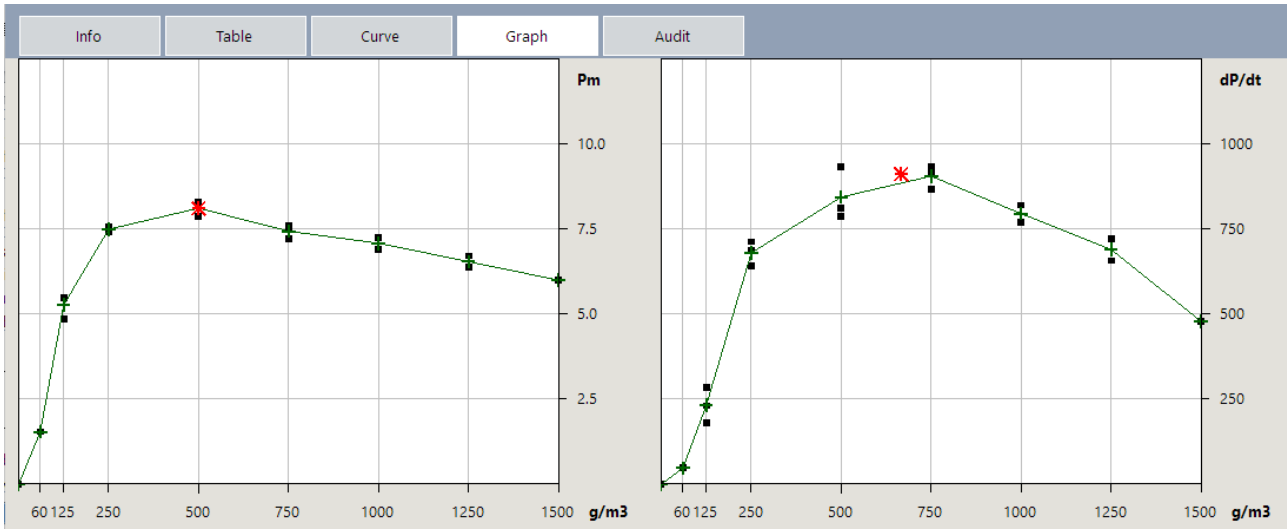

3.6 Audit

no	date	time	cause	event	value
23	19.11.2024	06:39	GERS	Test - 13	Dust: Pmax, Kmax
24	19.11.2024	06:43	GERS	Test - 14	Dust: Pmax, Kmax
25	19.11.2024	06:47	GERS	Test - 15	Dust: Pmax, Kmax
26	19.11.2024	06:50	GERS	Test - 16	Dust: Pmax, Kmax
27	19.11.2024	06:53	GERS	Test - 17	Dust: Pmax, Kmax

username	signature	authorization
GERS	Ali Basci	Administrator



Each KSEP file contains a list of users. If you are a member of this list, you have access according to your authorization (Administrator ... Operator).



The audit data are stored coded in the KSEP file!

3.7 Report

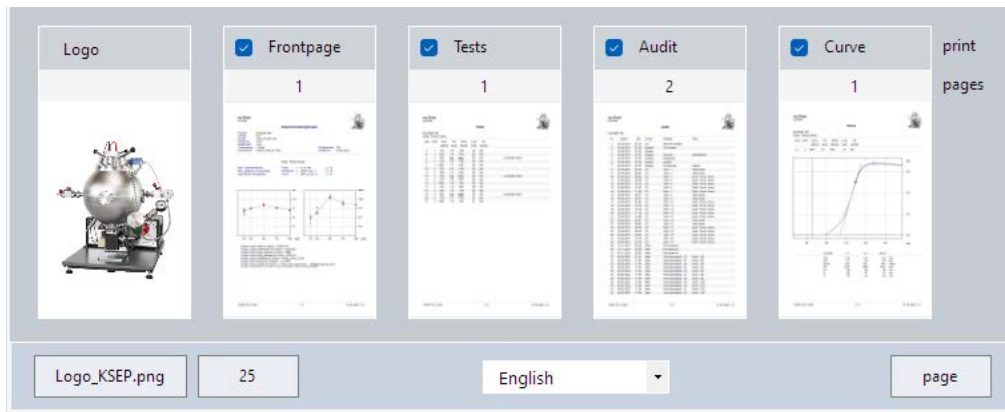

Select the **logo** for the report.
 You can define your company logo here.
 Requirements: Bitmap ".png" file
 The original width of the bitmap is automatically reduced to the width defined here when printing.

Select the **language** for the report.
 The program comes with some translation files.
 These can be easily adapted to other languages.
 See: [7.3 Translations](#)

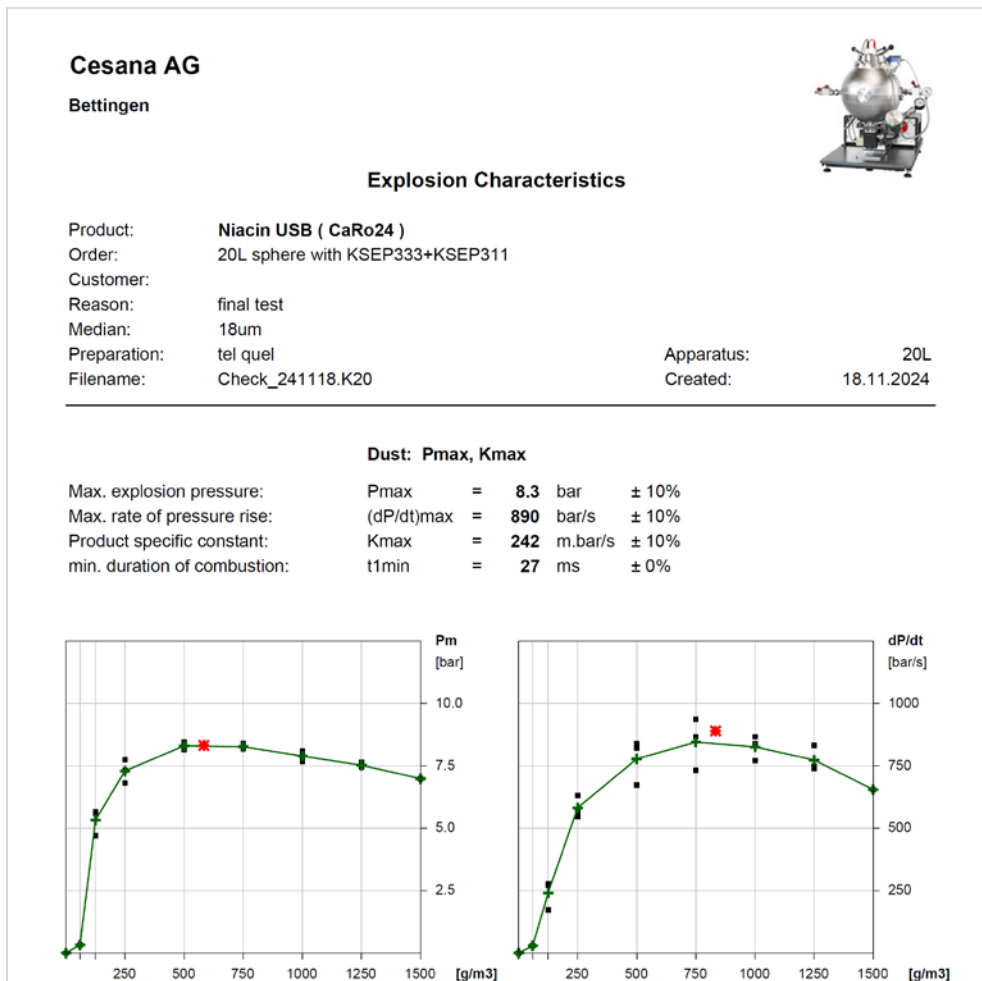

3.8 Test settings

3.8.1 20L with KSEP311

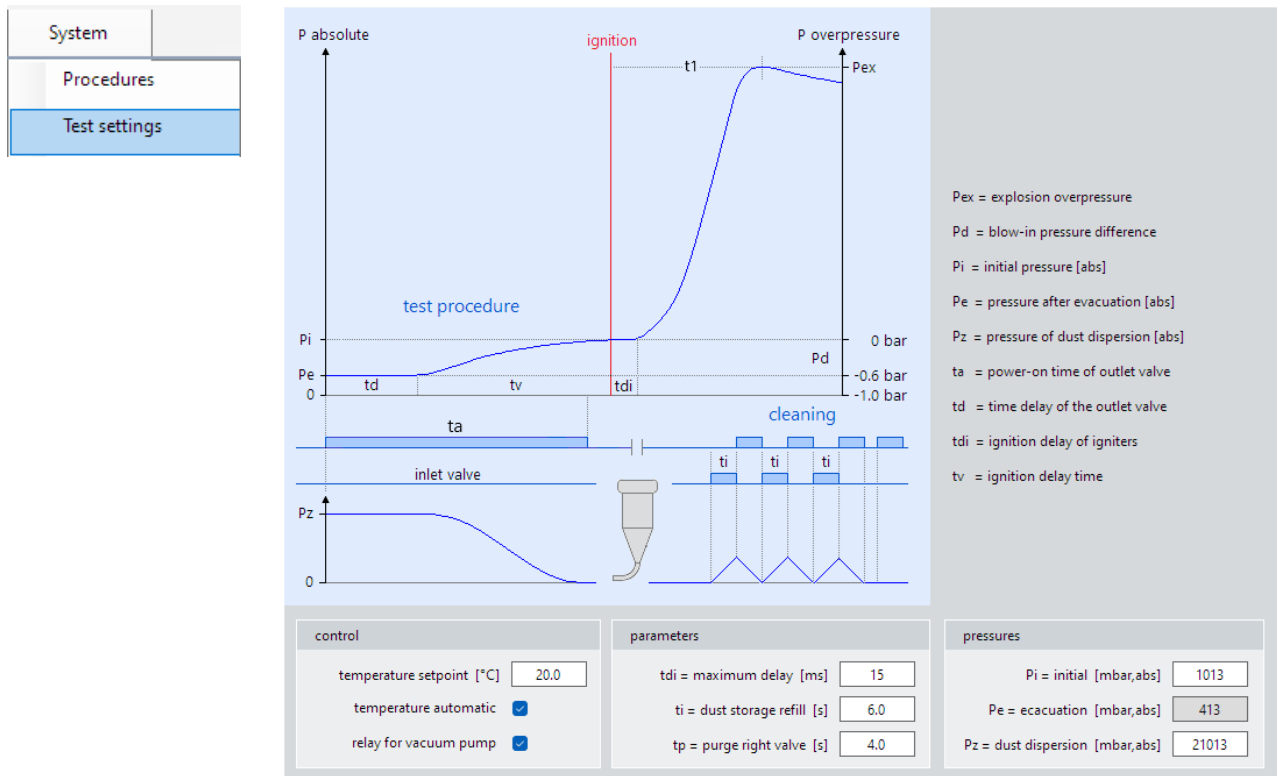

control temperature automatic: According to ISO/IEC 80079: Initial temperature = **20°C ± 5°C**

Due to the high test frequency, the sphere must be kept at the operating temperature of 20°C by means of water cooling. With an external solenoid valve, the KSE333 can control the jacket temperature of the sphere. This saves a lot of cooling water.

relay for vacuum pump: The vacuum pump is switched on only when required.

pressures According to standards, the following applies: Initial pressure Pi = **1013** mbar.

These pressure specifications are calculated automatically as follows and are only to be changed for special test conditions:

	Pi (Sphere + Dust storage)	Pe (Sphere)	Pz (Dust storage)
Volume x Pressure	20.6L x 1013mbar =	20L x 413mbar +	0.6L x 21'013mbar

parameters tdi = maximum delay: Time delay of the igniters = time difference between the electrical activation of the igniters and the first pressure rise. Adds up to t_v and must be controlled. The maximum permissible time delay is defined here. If this is exceeded, an error message is issued..

ti = dust storage refill: Filling time for the dust storage during automatic rinsing.

tp = purge right valve: Flushing time for the right ball valve during cleaning.

3.8.2 20L with KSEP310

The KSEP333 electronics unit is backwards compatible with the old **KSEP310** pneumatic unit. However, the functionality is limited compared to the new pneumatic unit KSEP311.

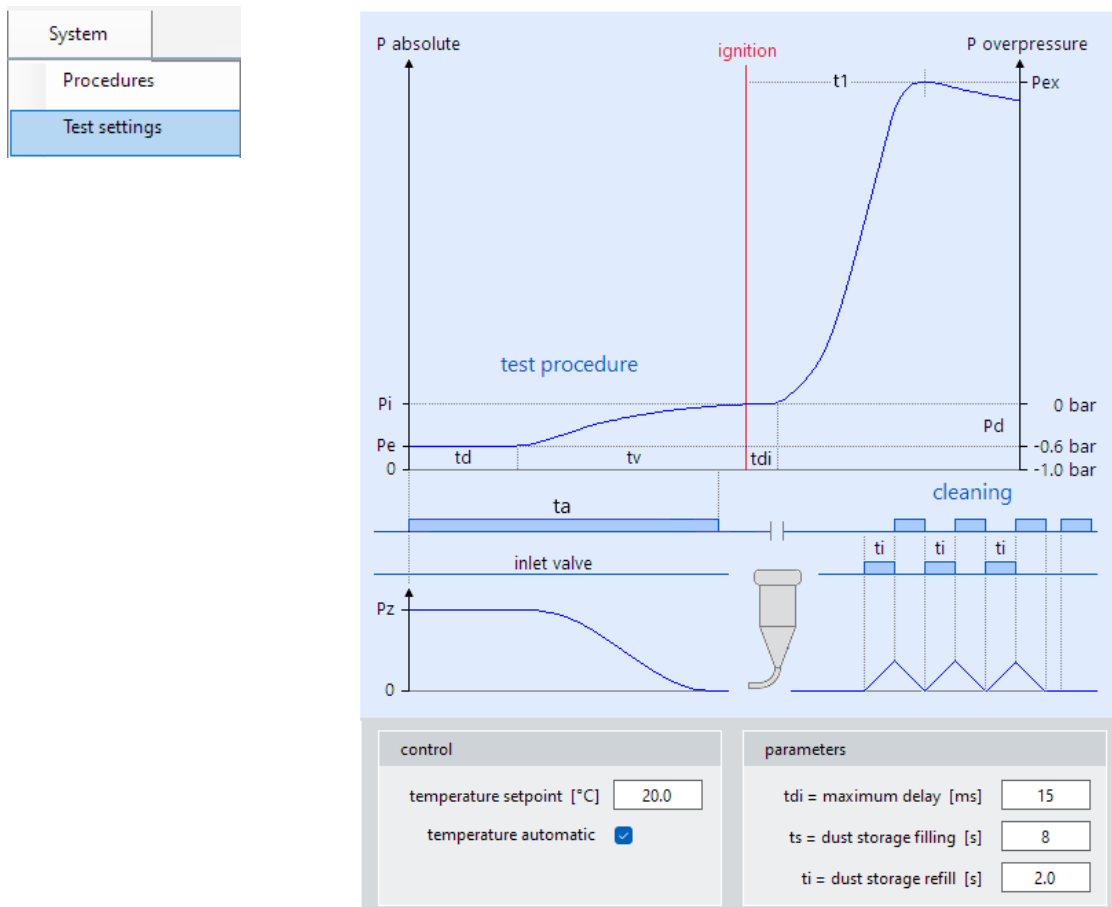

control temperature According to ISO/IEC 80079: Initial temperature = **20°C ± 5°C**

Due to the high test frequency, the sphere must be kept at the operating temperature of 20°C by means of water cooling. With an external solenoid valve, the KSE333 can control the jacket temperature of the sphere.

This saves a lot of cooling water.

tdi = maximum delay Time delay of the igniters = time difference between the electrical activation of the igniters and the first pressure rise. Adds up to t_v and must be controlled. The maximum permissible time delay is defined here. If this is exceeded, an error message is issued.

ts = dust storage filling Filling time for the dust storage container before the test. Must be sufficiently long to achieve a stable final value.

ti = dust storage refill Filling time for the dust storage during automatic rinsing.

3.8.3 1m3 vessel

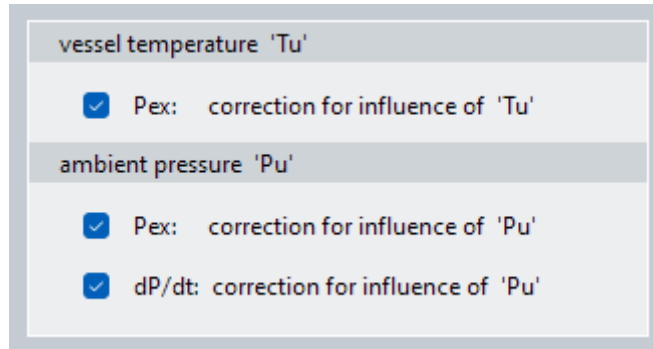
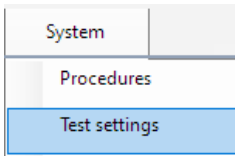

vessel temperature

According to the standards: *Before starting the test, the temperature in the in the 1 m³ container must be measured and recorded (initial temperature).*

The vessel temperature is measured and recorded by the KSEP333. The temperature influence on Pex can be calculated and automatically corrected. See: [1.5.4 Temperature](#)

ambient pressure

According to the standards, the following applies: *It must be ensured that atmospheric pressure prevails in the 1 m³ container when dust injection is initiated by opening the quick-opening valve on the dust container. The actual pressure in the 1 m³ container at the time of ignition (initial pressure Pi) must be determined and recorded.*

For the 1m3 container, the ambient pressure is taken as the initial pressure. This is measured and recorded by the KSEP333. The influence of the initial pressure on Pex and dP/dt can be calculated and automatically corrected. See: [1.5.5 Initial pressure](#)

The procedure corresponds in principle to the procedure with the pneumatic unit [KSEP311](#).

See: [3.3.3 Dust: Pmax, Kmax](#)

Info		Table		Curve		Graph		Audit		
curve	ok	test	series	conc.	Pm	dP/dt	tv	IE	Tu	Pu
▶	<input checked="" type="checkbox"/>	1	1	60	8.7	160	600	10kJ	(29°)	(958)
▶	<input checked="" type="checkbox"/>	2	1	125	8.9	160	600	10kJ	29°	(958)
▶	<input checked="" type="checkbox"/>	3	1	250	9.1	169	600	10kJ	(29°)	958
▶	<input checked="" type="checkbox"/>	4	1	500	9.4	169	600	10kJ	29°	1012

Vessel temperature **Tu** and ambient pressure **Pu** are registered during each test. Their influence on Pex and dP/dt is corrected according to your specifications. If the values are shown in brackets, then no correction was made for Tu or Pu.

4. Procedures for Dusts

4.1 General rules

Sample preparation: The product must be carefully dried e.g. 24 h at 50°C under vacuum or 24 h at 75°C under atmospheric pressure. The sample must be prepared in such a way that the median value $M < 63 \mu\text{m}$. Under certain circumstances, the test may also be performed in the as-received condition.

4.1.1 Test equipment

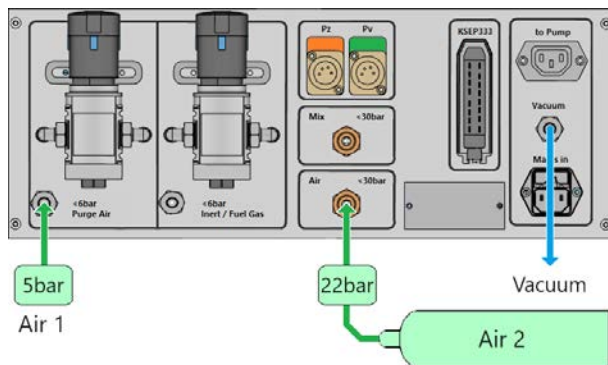

Air 1 (maximum 6 bar)

This air, usually from the laboratory compressed air network, is used to adjust the gas mixture in the sphere and for cleaning. Adjust to **1 bar** overpressure with the pressure regulator above (display = 1 bar). Maximum 2 bar overpressure = 3 bar, absolute!

Air 2 (22 bar)

This compressed air is used for the outlet valve and for the dust storage container. The precise storage pressure of 21 bar, absolute is regulated by the system. Therefore, the reduced pressure from the bottle must be slightly higher:

Nominal value = **22 bar overpressure** = 23 bar, absolute.

Only normal compressor compressed air from bottles may be used. With synthetic compressed air, strongly deviating explosion characteristics are measured. The pressure in the cylinder must be at least 40 bar.

Vacuum:

Before the start of each test, the 20-I-apparatus is evacuated in order to obtain normal pressure again (1013 mbar abs.) as the initial pressure for the dust explosion after the subsequent expansion of the dust reservoir air.

4.2 Dust - Explosion indices: P_{max} , $(dP/dt)_{max}$, K_{max}

Standards: EN 14034-1&2, ASTM E1226

4.2.1 Test Conditions

Procedure		=	Dust: P_{max}, K_{max}
Ignition source		=	Chemical igniters
Ignition energy	IE	=	2 x 5 kJ
Ignition delay time	tv	=	60 ms

4.2.2 Test Method

Settings

series	[g/m ³]	[g/20 l]	tv [ms]	IE [J]
1	250	5.0	60	10k

Preparation

Evacuate the sphere and fill the dust storage

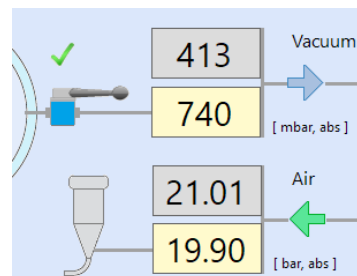

In a first test series, the maximum explosion overpressure and the maximum rate of pressure rise are determined over a wide range of concentrations. Starting with a low dust concentration of 60g/m³ (1.2g / 20-l), the concentration is increased in steps, until the maximum values for the explosion pressure and the rate of pressure rise have clearly been determined. The following steps must be used:

60; 125; 250; 500; 750; 1000; 1250; 1500 g/m³

After the first test series, the concentration range close to the observed maxima (P_{max} , $(dP/dt)_{max}$) is twice checked, i.e. the tests are repeated at the optimum concentration, the next higher and the next lower concentration. An example:

(Assuming, the maxima of P_m and (dP/dt) are at 250 resp. 500 g/m³)

1. series:	60,	125,	250,	500,	750,	1000 g/m ³
2. series:		125,	250,	500,	750	
3. series:		125,	250,	500,	750	

Test Evaluation



The maximum explosion pressure Pmax and the maximum pressure rise over time (dP/dt)max are given as the average of the maximum values of each series, called the **average of maxima** for short.

Pm [series n] = maximum value of each series

$$P_{max} = (P_m [series 1] + P_m [series 2] + P_m [series 3]) / 3$$

(dP/dt)m [series n] = maximum value of each series

$$(dP/dt)_{max} = (dP/dt [series 1] + dP/dt [series 2] + dP/dt [series 3]) / 3$$

$$K_{max} = 0.27144 \times (dP/dt)_{max}$$

Check of the results

Pmax is the mean value of the maxima of three series of tests.

Each of the maxima must not deviate by more than **10% of Pmax**

Otherwise this series must be repeated !

(dP/dt)max is the mean value of the maxima of three series of tests.

Each of the maxima must not deviate more than the values given in the table below.

Otherwise this series must be repeated !

(dP/dt)max	Kmax	Deviation
≤ 185	≤ 50	± 30 %
186 - 370	51 - 100	± 20 %
371 - 740	101 - 200	± 12 %
> 740	> 200	± 10 %

This check will be done automatically. Faulty series will be highlighted in red color.

This series must be repeated !

Results of ... the test

dP/dt	Test: 24 (2) 750 [g/m3]		
	(A)	(B)	result
Pex	7.8	7.8	7.8 bar
Pm	8.2	8.2	8.2 bar
dP/dt	934	941	938 bar/s
Pd	0.64	0.64	0.64 bar
td	35	35	35 ms
tv	60	60	60 ms
t1	27	26	27 ms
tdi	7	7	7 ms

the preparation

dP/dt	Test: 24 (2) 750 [g/m3]		
	setpoint	effective	FS [%]
Pv vacuum [mbar]	413	415	0.2
Pz air [bar]	21.01	21.02	0.0
Pi calculated* [mbar]	1013	1014*	
ta AV power-on [ms]	85		

19.11.2024 / 07:44

In addition to the explosion characteristics, the results of the preparation can be displayed. The absolute initial pressure Pi is calculated from the measured values of Pv and Pz.

4.3 Dust - Lower Explosion Limit (LEL, MEC)

Standards: EN 14034-3, ASTM E1515

4.3.1 Test Conditions

Procedure	=	Dust: LEL
Ignition source	=	Chemical igniters
Ignition energy	IE	= EN: 2 x 1kJ, ASTM: 1 x 2.5kJ
Ignition delay time	tv	= 60 ms

4.3.2 Test Method

Settings

series	[g/m ³]	[g/20 l]	tv [ms]	IE [J]
1	30	0.6	60	2k

Preparation

Evacuate the sphere and fill the dust storage

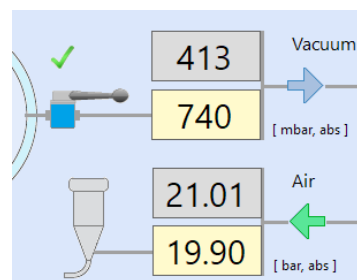

EN 14034-3: This procedure should be started with a dust concentration of 125 g/m³ or other concentration at which an explosion occurs and repeated by reducing in steps of 50% of the previous concentration, as shown below:

750; 500; 250; 125; 60; 30 g/m³

This procedure must be repeated down to the concentration at which no explosion occurs. The highest concentration of combustible dust at which no ignition occurs in **three** consecutive tests is specified as the lower explosion limit (LEL).

ASTM E1515 requires the following for calibration: The LEL must agree to $\pm 10\%$ or 5 g/m³, whichever is greater. We therefore recommend reducing the step size of the dust concentrations in the ignition / non-ignition range to **5 g/m³**.

Test Evaluation (EN-14034-3 mit ZE = 2 x 1kJ)

P _{ex} [bar]	P _m [bar]	Decision:
< 0.5	< 0.2	no ignition
≥ 0.5	≥ 0.2	ignition



This determination is naturally very sensitive to product residues from previous tests. It has thus proved advisable to insert a blank test (igniters only, no dust) between the individual tests with dust to remove the residues following cleaning.

4.4 Dust - Explosibility

Standards: ISO/IEC 80079-20, ASTM E1226

4.4.1 Test Conditions

Procedure		= Dust: Explosibility
Ignition source		= Chemical igniters
Ignition energy	IE	= ISO/IEC: 2 x 1kJ, ASTM: 1 x 2.5kJ
Ignition delay time	tv	= 60 ms

4.4.2 Test Method

Settings

series	[g/m ³]	[g/20 l]	tv [ms]	IE [J]
1	30	0.6	60	2k

Preparation

Evacuate the sphere and fill the dust storage

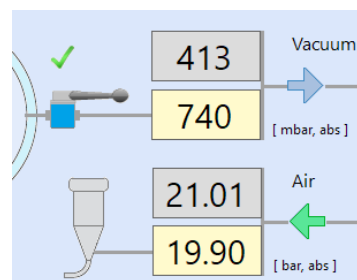

The 20-l-sphere and the dust storage chamber must be cleaned thoroughly before each test. A test series is initiated, starting with a dust concentration of 30g/m³.

e.g. 30, 60, 125, 250, 500, 750, 1000, 1250, 1500, 1750, 2000 g/m³

Test Evaluation (ISO/IEC 80079-20 mit ZE = 2 x 1kJ)

Pex [bar]	Pm [bar]	Decision:
< 0.5	< 0.2	no ignition
≥ 0.5	≥ 0.2	ignition



A dust which cannot be induced to explode over a wide range of concentrations (normally from 30g/m³ to 2000g/m³) with an ignition energy of IE = 2 x 1 kJ (chemical igniters) is classified as **not explosible**.

This means that most probably the dust cannot be exploded at all, except by application of even stronger ignition sources (IE > 2 kJ).



Decision thresholds for ignition:

ISO/IEC 80079-20, 20-l-Sphere, $P_{ex} \geq (* \text{Igniter pressure} + 0.3 \text{ bar})$
 *Igniter pressure calculated (see 1.4.2) = 0.3 bar -> $P_{ex} \geq (P_m + 0.3) == 0.5 \text{ bar}$
 *Igniter pressure measured, typical = 0.2 bar -> $P_{ex} \geq (0.2 + 0.3) == 0.5 \text{ bar}$

4.5 Dust - Limiting Oxygen Concentration (LOC)

Standards: EN 14034-4, ASTM E2931

The inert gas/air mixture is automatically generated in the sphere and in the dust storage container according to the partial pressure method.

4.5.1 Test equipment

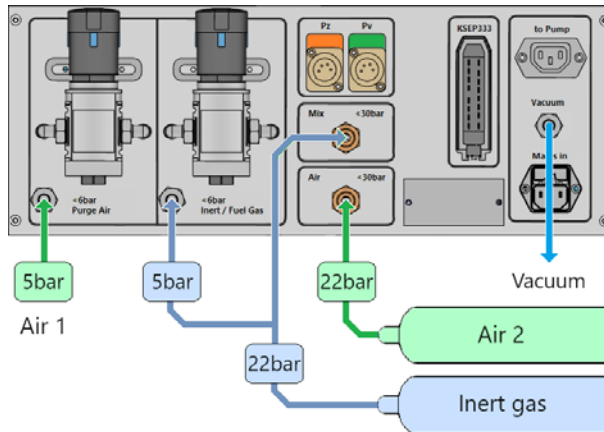

Air 1 (maximum 6 bar)

This air, usually from the laboratory compressed air network, is used to adjust the gas mixture in the sphere and for cleaning. Adjust to **1 bar** overpressure with the pressure regulator above (display = 1 bar). Maximum 2 bar overpressure = 3 bar, absolute!

Air 2 (22 bar)

This compressed air is used for the outlet valve and for the dust storage container. The precise storage pressure of 21 bar, absolute is regulated by the system. Therefore, the reduced pressure from the bottle must be slightly higher:

Nominal value = **22 bar overpressure** = 23 bar, absolute.

Only normal compressor compressed air from bottles may be used. With synthetic compressed air, strongly deviating explosion characteristics are measured. The pressure in the cylinder must be at least 40 bar.

Inert gas (22 bar)

This compressed air is used for filling the dust storage container. The precise storage pressure of 21 bar, absolute is regulated by the system. Therefore, the reduced pressure from the bottle must be slightly higher:

Nominal value = **22 bar overpressure** = 23 bar, absolute.

Inert gas (maximum 6 bar)

This gas is used to adjust the gas mixture in the sphere. The pressure from the bottle must be further reduced to approx. 5 bar. Then adjust to **1 bar** overpressure with the pressure regulator above (display = 1 bar). Maximum 2 bar overpressure = 3 bar, absolute!

Vacuum:

Before the start of each test, the 20-I-apparatus is evacuated in order to obtain normal pressure again (1013 mbar abs.) as the initial pressure for the dust explosion after the subsequent expansion of the dust reservoir air.

4.5.2 Test Conditions

Procedure	=	Dust: LOC
Ignition source	=	Chemical igniters
Ignition energy	IE	= EN: 2 x 1kJ, ASTM: 1 x 2.5kJ
Ignition delay time	tv	= 60 ms

4.5.3 Test Method

Settings

O2 [%] = Oxygen concentration

Inexpensive inert gas cylinders contain a residual oxygen content.

Preparation

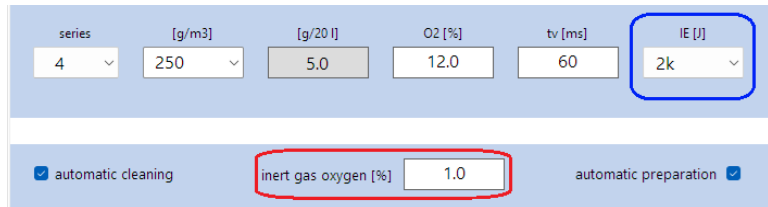

Same oxygen concentration in sphere and dust storage

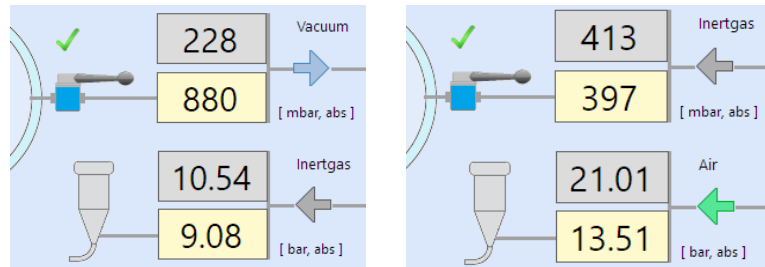

Method 1 (EN-14034-4): After an initial series of tests in normal air (O2 = 21%), measurements are carried out over a wide range of dust concentrations, e.g. at 15% O2.

If these tests are positive, a limit value can be estimated by extrapolating the two dP/dtmax values towards 0. At this value, explosion tests are now carried out over a wide concentration range of the dust. If these are positive, the tests are repeated with an O2 content reduced by 1%, and if negative, with an O2 content increased by 1%, and continued in this way until no more ignitions of the dust/air mixtures occur.

3 non-ignition tests per dust concentration must be performed.

Test evaluation (EN-14034-4 mit ZE = 2 x 1kJ)

Pex [bar]	Pm [bar]	Decision:
< 0.5	< 0.2	no ignition
≥ 0.5	≥ 0.2	ignition



With decreasing oxygen concentration, the optimum dust concentration is shifted to lower values. The tests must therefore also be performed especially in this concentration range.

Method 1 (EN-14034-4)

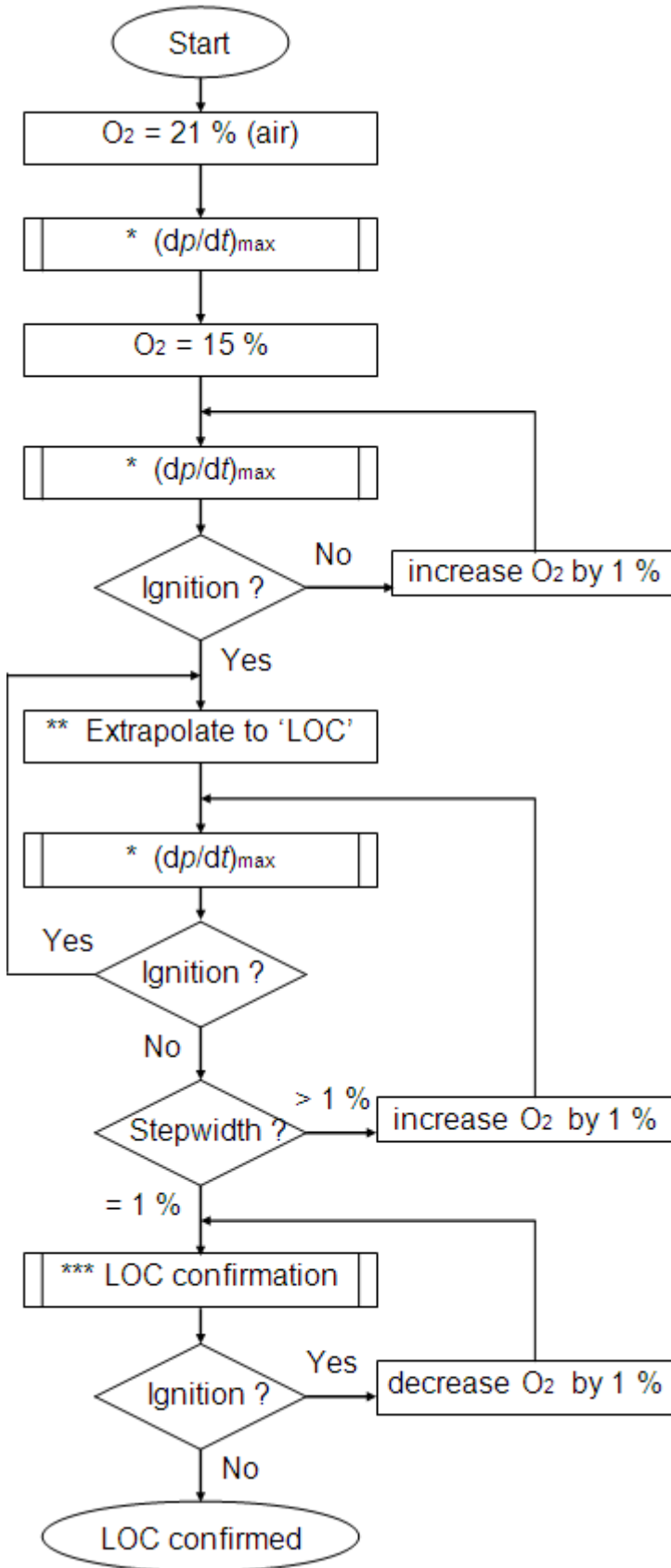

*** (dp/dt)max- Determination**

Determination of (dp/dt)max by changing the dust concentration. The following steps are to be used: 60, 125, 250, 500, 750, 1000, 1250, 1500g/m3. For most dusts, start with a dust concentration of 500g/m3.

**** Extrapolation to LOC**

The values of (dp/dt)max are plotted versus O2 to obtain an estimate of LOC by linear extrapolation to (dp/dt)max = 0 bar/s.

***** LOC confirmation**

Confirmation of the LOC by 3 tests without ignition at any dust concentration, which at a 1 % higher O2-concentration led to an explosion.

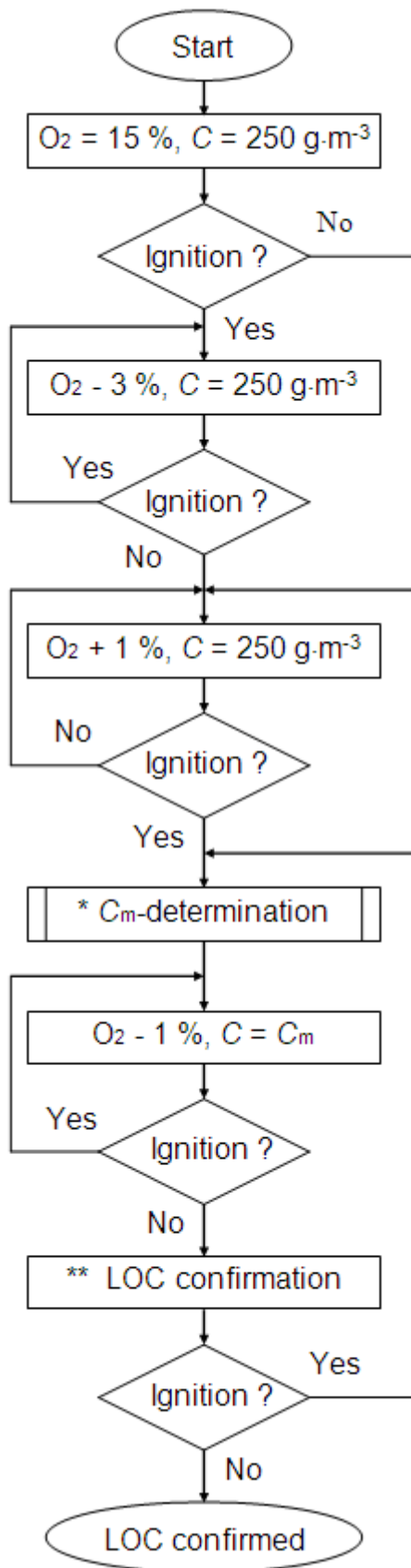
Method 2 (EN-14034-4)

For most of the dusts it is advisable to start with a dust concentration of $C = 250\text{g/m}^3$ and an oxygen concentration of 15%.

*** Cm- Determination**

C_m is the dust concentration at which at any given O_2 concentration the highest explosion pressure P_{ex} occurs.

The following steps are to be used:

60, 125, 250, 500, 750, 1000, 1250, 1500g/m³

***** LOC confirmation**

Confirmation of the LOC by 3 tests without ignition at any dust concentration, which at a 1 % higher O_2 -concentration led to an explosion.

Results ...

of the test

dP/dt Test: 56 (4) 250 [g/m3]				
	(A)	(B)	result	
Pex	0.34	0.34	0.34	bar
Pm	0.02	0.02	0.02	bar
dP/dt	0	0	0	bar/s
Pd	0.67	0.66	0.66	bar
td	35	35	35	ms
tv	60	60	60	ms
t1	72	64	68	ms
tdi	9	10	10	ms

of preparation

dP/dt Test: 56 (4) 250 [g/m3]				
	setpoint	effective	FS [%]	
Pv vacuum [mbar]	237	238	0.1	
Pv inert gas [mbar]	413	408	-0.5	
Pz air [bar]	21.01	21.06	0.2	
Pz inert gas [bar]	9.99	10.04	0.2	
Pi calculated* [mbar]	1013	1010*		
oxygen calculated* [vol%]	12.0	12.0*		
inertgas oxygen [vol%]	1.0			
ta AV power-on [ms]	84			

Inaccuracies during preparation and leaks in the sphere can influence the mixture. The effective gas mixture can be calculated by precisely measuring the absolute pressures in the sphere and dust storage. The calculated oxygen concentration is transferred to the table.

This also applies to the "hybrid mixture" and "gas" test methods.

Advantages

- Only one inert gas cylinder is required for all oxygen concentrations.
- The same oxygen concentration is present in the sphere and in the dust storage.
- Distortions due to leaks must be taken into account.
- The absolute pressures measured during preparation are known.
- The calculated oxygen concentration is therefore much more accurate.
- The gas mixture is prepared very quickly.

Accuracy according	O2 measurement $\pm 0.1\%$ volume fraction
to EN-14034-4:	O2 tolerance $\pm 0.3\%$ volume fraction
	O2 steps = 1%

For mixture settings according to the partial pressure method, a tolerance of $\pm 0.3\%$ corresponding to $\pm 3\text{mbar}$ must be observed.

5. Procedure for Hybrid Mixtures

5.1 Test equipment

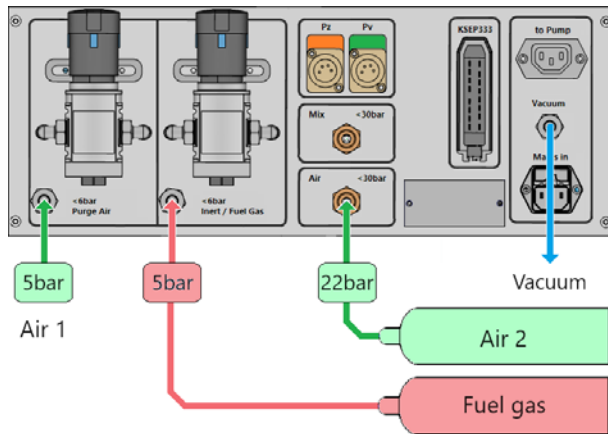

Air 1 (maximum 6 bar)

This air, usually from the laboratory compressed air network, is used to adjust the gas mixture in the sphere and for cleaning. Adjust to **1 bar** overpressure with the pressure regulator above (display = 1 bar). Maximum 2 bar overpressure = 3 bar, absolute!

Air 2 (22 bar)

This compressed air is used for the outlet valve and for the dust storage container. The precise storage pressure of 21 bar, absolute is regulated by the system. Therefore, the reduced pressure from the bottle must be slightly higher:

Nominal value = **22 bar overpressure** = 23 bar, absolute.

Only normal compressor compressed air from bottles may be used. With synthetic compressed air, strongly deviating explosion characteristics are measured. The pressure in the cylinder must be at least 40 bar.

Fuel gas (maximum 6 bar)

This gas is used to adjust the gas mixture in the sphere. The pressure from the bottle must first be reduced to approx. 5 bar. Then adjust to **1 bar** overpressure with the pressure regulator above (display = 1 bar). Maximum 2 bar overpressure = 3 bar, absolute!

Vacuum:

Before the start of each test, the 20-I-apparatus is evacuated in order to obtain normal pressure again (1013 mbar abs.) as the initial pressure for the dust explosion after the subsequent expansion of the dust reservoir air.

5.2 Explosion indices: P_{max} , $(dP/dt)_{max}$, K_{max}

To create the hybrid mixtures, propane, as a substitute fuel gas for solvent vapors, is added to the combustion air in graduated concentrations.

5.2.1 Test Conditions

Procedure		= Hybrid: P_{max}, K_{max}
Ignition source		= Chemical igniters
Ignition energy	IE	= 2 x 5 kJ
Ignition delay time	tv	= 60 ms
Dispersion pressure	Pz	= 20 bar (21 bar absolute, pre-evacuation)

5.2.2 Test Method

Settings

series	[g/m ³]	[g/20 l]	C3H8 [%V/V]	tv [ms]	IE [J]
1	125	2.5	4.5	60	10k

Preparation

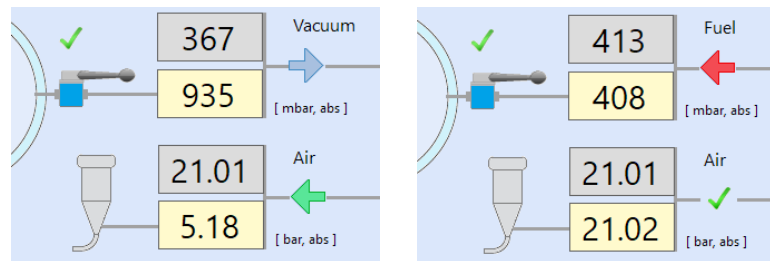

After the first investigation in normal air (see: [4.2 Dust - Explosion indices](#)), the tests will be repeated after adding of a certain amount of flammable gas into the normal air. The tests are done over a wide range of concentration until the maximum values of the hybrid mixtures are clearly receding. Afterwards, two further test series, as described above, have to be carried out.

For these tests the gas concentration most important for the judgment of the safety situation has to be chosen. Without that it is recommended to carry out the tests over a wide range of gas concentrations. By this test procedure the optimum values of the hybrid mixtures can be obtained.



The K_{max} values of the hybrid mixtures occur at the stoichiometric gas concentrations of the flammable gas (K_{max} -value). For propane this concentration is approximately 4.25 - 4.5%

Result of the preparation

Inaccuracies during preparation and leaks in the sphere can influence the mixture. The effective gas mixture can be calculated by precisely measuring the absolute pressures in the sphere.

The calculated gas concentration is transferred to the table.

	setpoint	effective	FS [%]
Pv vacuum [mbar]	367	367	-0.1
Pv fuel gas [mbar]	413	414	0.1
Pz air [bar]	21.01	21.01	0.0
Pi calculated* [mbar]	1013	1013*	
fuel calculated* [vol%]	4.5	4.6*	

6. Procedure for Gas (quiescent)

6.1 Test equipment

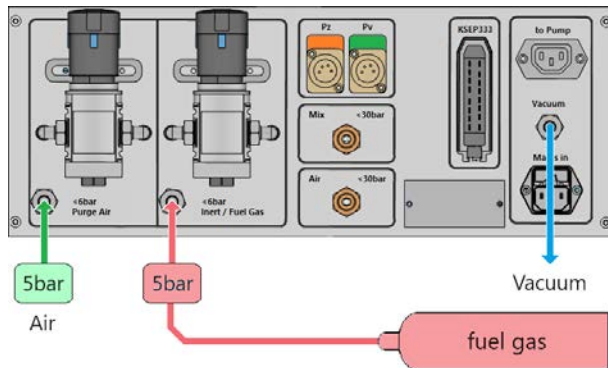

Air (maximal 6 bar)

This air, usually from the laboratory compressed air network, is used to adjust the gas mixture in the sphere and for cleaning. Adjust to **1 bar** overpressure with the pressure regulator above (display = 1 bar). Maximum 2 bar overpressure = 3 bar, absolute!

Fuel gas (maximum 6 bar)

This gas is used to adjust the gas mixture in the sphere. The pressure from the bottle must first be reduced to approx. 5 bar. Then adjust to **1 bar** overpressure with the pressure regulator above (display = 1 bar). Maximum 2 bar overpressure = 3 bar, absolute!

Vacuum:

Before the start of each test, the 20-l-apparatus is evacuated in order to obtain normal pressure again (1013 mbar abs.) as the initial pressure for the dust explosion after the subsequent expansion of the dust reservoir air.



In principle, the explosion characteristics can be determined either in the quiescent or in the turbulent state of the gas (solvent-vapor)/air mixtures. In the following, it is assumed that the gas mixtures are in the quiescent state at the moment of ignition. For this reason, a plug is screwed in instead of the rebound nozzle, which seals the apparatus tightly at the bottom.

6.2 Gas - Explosion indices

It is common practice to determine the explosion characteristics of gases and solvent vapors as far as possible at room temperature and normal pressure, and to use a continuous spark gap as ignition source, the energy of which is in the order of magnitude of 10 J. The ignition source should be a spark gap.

During investigations in the quiescent state, the fuel is added directly to the 20-I sphere and not via the dust reservoir. Thus, there is also no expansion pressure of the reservoir air ($P_d = 0$ bar). Therefore, set $t_v = 0$ ms. The ignition signal then occurs immediately after the test is triggered and the evaluation of P_d and t_d is suppressed.

The desired gas/air mixtures can be easily created using the partial pressure method. It has proven useful to check the gas/air mixture generated in this way from time to time using suitable measuring equipment.

6.2.1 Test Conditions

Procedure	=	Gas: Pmax, Kmax
Ignition source	=	Permanent Spark
Ignition energy	IE	= 10 J
Ignition delay time	t_v	= 0 ms

6.2.2 Test Method: Pmax, Kmax

Settings

Preparation of sphere

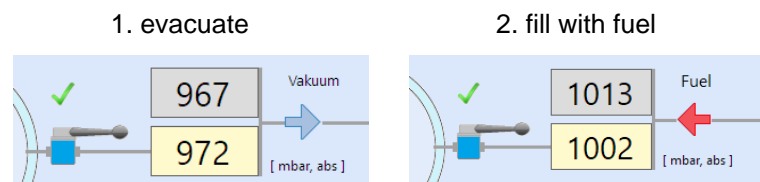

In a first test series, the maximum explosion pressure and the maximum rate of pressure rise are determined over a wide range of concentrations. Starting with a gas concentration greater than the LEL, the concentration is either increased or decreased in steps of at most 1% , until the maximum values for the explosion pressure and the rate of pressure rise have clearly been covered.

After the first test series, the concentration range close to the observed maxima (P_{max} , K_{max}) is twice checked, i.e. the tests are repeated at the optimum concentration, the next higher and the next lower concentration. An example:

(Assuming, the maxima of P_m and (dP/dt) are at 4.5%)

1. series:	2.0,	3.0,	3.5,	4.0,	4.5,	5.0,	5.5 %
2. series:				4.0,	4.5,	5.0	
3. series:				4.0,	4.5,	5.0	

Test Evaluation



The explosion indices Pmax and (dP/dt)max are defined as the mean values of the maximum values of each series (total **3 series**).

Subsequently, the explosion index Kmax is calculated from the above (dP/dt)max.

P_m [series n] = maximum value of each series

$$P_{max} = (P_m \text{ [series 1]} + P_m \text{ [series 2]} + P_m \text{ [series 3]}) / 3$$

(dP/dt)m [series n] = maximum value of each series

$$(dP/dt)_{max} = (dP/dt \text{ [series 1]} + dP/dt \text{ [series 2]} + dP/dt \text{ [series 3]}) / 3$$

$$K_{max} = 0.27144 \times (dP/dt)_{max}$$

6.2.3 Test Method: LEL

The 20-I-sphere has to be cleaned thoroughly before each test. A test series is initiated, starting with gas concentrations of an integral multiple of 0.25% for example 2 or 3%.

The series is continued with a systematic increase of the gas concentration until ignition of the gas/air mixture is observed. Repeat the test with a gas concentration 0.25% lower, and continue to reduce the concentration in further tests until a concentration is reached at which no ignition of the gas/air mixture is observed in three successive tests.

For the determination of the **UEL (Upper Explosion Limit)** the LEL-procedure can be used accordingly.

To obtain accurate values for the LEL or UEL, **3** negative tests for each concentration must be observed.

Test Evaluation (IE = 10 J)

Pex [bar]	Pm [bar]	Decision:
< 0.1	< 0.1	no ignition
≥ 0.1	≥ 0.1	ignition



The lower explosion limit LEL as well as the upper explosion limit UEL are reported as those concentrations at which a gas explosion is just not possible in **3** successive tests. If only one test series is carried out (1 negative test), the value for LEL or UEL has to be reported as approximately ... %.

Result of preparation

Inaccuracies during preparation and leaks in the sphere can influence the mixture. The effective gas mixture can be calculated by precisely measuring the absolute pressures in the sphere. **The calculated gas concentration is transferred to the table.**

dP/dt Test: 47 (1) 4.7 [%V/V]			
	setpoint	effective	FS [%]
Pv vacuum [mbar]	967	966	-0.2
Pv fuel gas [mbar]	1013	1013	0.0
fuel calculated* [vol%]	4.5	4.7*	

7. Utilities

7.1 Procedures

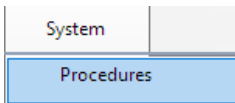

The grouping of the tests according to test procedures makes it much easier to work with the apparatus, because both the test parameters and the graphical representations are very different.



The default values comply with the CEN regulations. Adaptations to e.g. ASTM - LEL/MEC, are easily possible here.

For the **1m3 vessel** with electro-pneumatic valve, the standard ignition delay time $t_v = 600\text{ms}$ must be adjusted to the delay time of the valve.

current KSEP-file The test parameters of the **current** file are displayed and can be adjusted. Changes are transferred directly to the file.

new KSEP-file These are the general test parameters. For each new test, these parameters are automatically taken.



Return to the default CEN - settings.
(only for "new KSEP-file")

7.2 Export



Tab

Comma

Semicolon

Info

Results

Tests - table

Audit - table

Curve - Results

Curve - Data

Data and graphics can be exported very easily to other programs. First select the procedure to be exported.

The data is copied to the Windows clipboard according to your specifications and can be easily pasted from there into other Windows programs, e.g. Excel, Word.

Excel

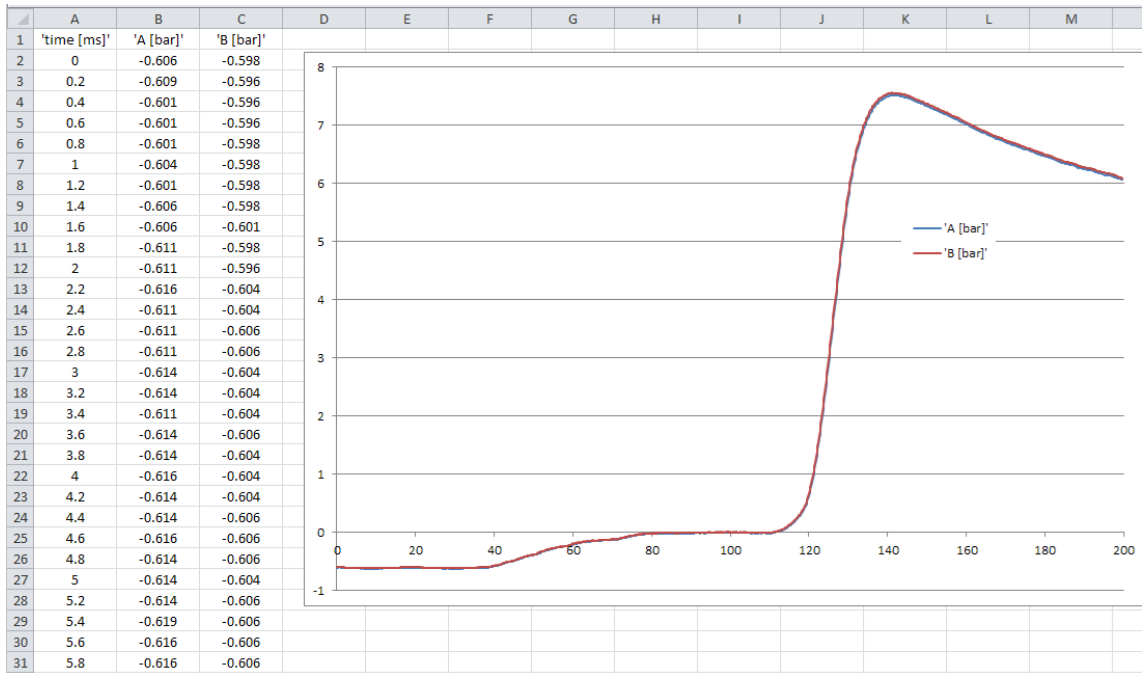

Word

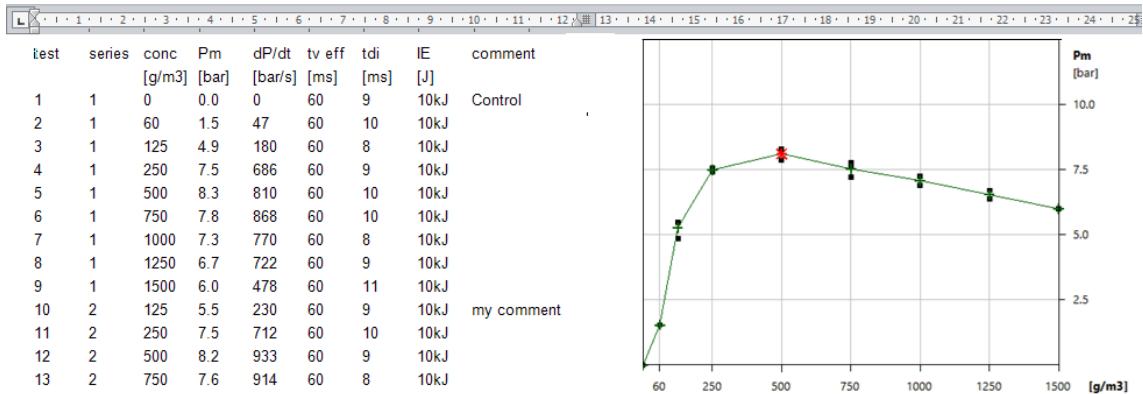

7.3 Translations

In the KSEP program, German and English are permanently programmed for the test report and user information. In addition, translation files are supplied in other languages. If your language is not listed, you can add your translation file using the following instructions.

7.3.1 Report

Target: test report in a different language. In the following example in French.

1. Open the Excel sheet „**K8_Repo_Example.xlsx**“ and write your translation in the 2nd column.

2	Filename:	K8_Repo_Francais.txt	integrated in software
3			
4	Des {key}	Francais	English
5	{ExIndices}	Caractéristiques d'explosion	Explosion Characteristics
6	{Gas}	Gaz	Gas
7	{Dust}	Poussière	Dust
8	{Pmax}	Surpression d'explosion	Explosion overpressure
9	{Pmax_max}	max. Surpression d'explosion	Max. explosion pressure
10	{dP_dt}	Vitesse de montée	Rate of pressure rise
11	{dP_dt_max}	max. Vitesse de montée	Max. rate of pressure rise
12	{Kmax}	Constante spécifique	Product specific constant

2. Copy both fields with the keywords {...} and their translations into the clipboard and insert them into the **Microsoft Editor**.

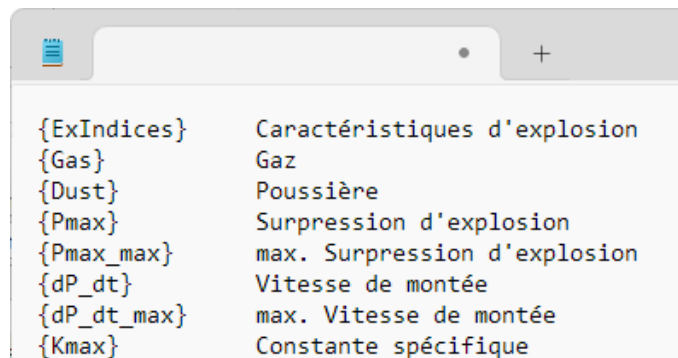

3. Save the file as “**K8_Repo_Francais.txt**”.
The file name must begin with “**K8_Repo_**”.
Start the KSEP program.
The newly added language is displayed in **Settings / Setup 1** and in **Report**.
All characters supported by the Microsoft operating system can be used.
Example: K8_Repo_日本語.txt

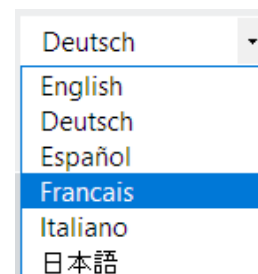

7.3.2 Information

Target: Messages and instructions for the user in another language.

The following example is in French.

1. Open the Excel sheet „**K8_Info_Example.xlsx**“ and write your translation in the 2nd column.

2	Filename:	K8_Info_Francais.txt	integrated in software
3			
4	key	Francais	English
5	{GoBack}	retourner	go back
6	{GoNext}	prochaine étape	next step
7	{SaveSettings}	enregistrer les paramètres et quittez	save settings and close
8	{SelectDevice}	choisir l'interface CAN	select a CAN-device
9	{CANnumber}	changer le numéro de l'interface CAN	change number of CAN-device
10	{Cancel}	annuler	cancel
11	{CancelEsc}	Annuler (touche Esc)	cancel (Esc key)
12	{Driver}	installez le pilote maintenant	install the driver now
13	{BaroPress}	Pression barométrique au niveau de la mer =	barometric pressure at sea level =

2. Copy both fields with the keywords {...} and their translations into the clipboard and insert them into the **Microsoft Editor**.

```
{GoBack}      retourner
{GoNext}      prochaine étape
{SaveSettings} enregistrer les paramètres et quittez
{SelectDevice} choisir l'interface CAN
{CANnumber}   changer le numéro de l'interface CAN
{Cancel}      annuler
{CancelEsc}   Annuler (touche Esc)
{Driver}      installez le pilote maintenant
{BaroPress}   Pression barométrique au niveau de la mer =
```

3. Save the file as “**K8_Info_Francais.txt**”.
The file name must begin with “**K8_Info_**”.

Start the KSEP program.

The newly added language is displayed in **Settings / Setup 1**

All characters supported by the Microsoft operating system can be used.

Example: K8_Info_日本語.txt

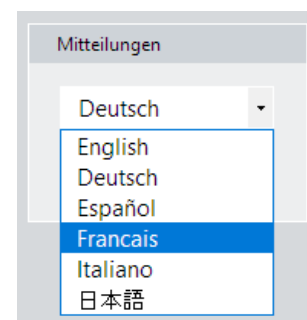

The on-screen texts remain unchanged in English. However, all the information important to the user is translated and displayed in their language. Examples:

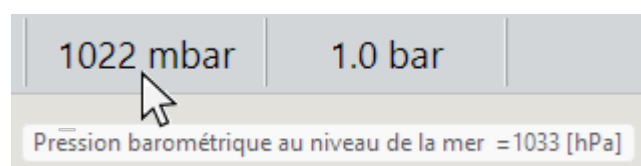
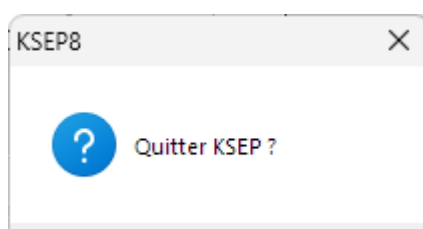

7.4 System - Info

Help
Quick guide
Manual
Annex
Update
Info

This utility shows an overview of the most important settings, the date of the files and information about your PC and its operating system.

For software problems, please copy this information to the clipboard, paste it into an email and send it with a description of the problem to:

info@cesana-ag.ch

titel	KSEP 8.0
generation	KSEP80
setup on	06.01.2025
your plant	Cesana AG
your site	Korfos
your e-mail	info@cesana-ag.ch
release:	year - week
KSEP333	2502
Flash C_KMCA	2443
system:	
OS	Microsoft Windows 11 Pro
Platform	X64 (64bit)
PCAN-driver	PCAN_USB 4.4.0.16619
PCAN-API	4.4.0.288
screen (WxH)	1920 x 1152
font (WxH)	14 x 15

8. Troubleshooting

8.1 Error in the results



P_{ex} and dP/dt are dependent on the dust concentration. The steps in dust concentration are quite large e.g. 125, 250, 500, 750 g/m³. The optimum dust concentration is often in between. However, dust distribution and concentration are subject to fluctuations. We take this into account by taking the average of 3 series. Repetitions with always the same dust concentration for testing the apparatus are therefore not very useful.



8.1.1 P_{max} too high or too low

The maximum explosion overpressure P_{max} is the result of combustion from the fuel with the atmospheric oxygen and is largely independent of the turbulence. In case of deviation from the expected value, these may be the causes:

- a) At ignition time, non-atmospheric pressure (1013 mbar) is in the sphere.
 P_{max} is directly proportional to the initial pressure P_i = pressure at ignition time.
 Possible cause of error: loss of vacuum due to leakage of the sphere?
- b) Temperature effect: P_{max} decreases practically linearly with increasing temperature. This is due to the reduced oxygen content. Due to the high test frequency, the explosion sphere must be kept at an operating temperature of approx. 20°C by means of water cooling.



8.1.2 K_{max} too high or too low

- a) At ignition time, non-atmospheric pressure (1013 mbar) is in the sphere.
 K_{max} is directly proportional to the initial pressure P_i = pressure at ignition time.
 Possible cause of error: loss of vacuum due to leakage of the sphere?
- b) P_{max} is correct, K_{max} too low:
 The turbulence during dust dispersion has a decisive influence on the K_{max} value.
 A reduction in turbulence usually results in a weakening of the explosion severity.
 Possible causes:
 - Bores of the rebound nozzle clogged?
 - Deposits on the inner wall of the sphere?
 - Pressure drop in Dust storage, leakage?
 - Ignition delay time t_{di} too long
 - Ignition delay time $t_v > 60ms$
 - Outlet valve dirty?
- c) P_{max} is correct, K_{max} too high:
 The turbulence during dust dispersion has a decisive influence on the K_{max} value.
 An increase in turbulence usually results in an increase in explosion severity.
 Possible causes:
 - Igniter influence: Superimposed oscillations during pressure rise?
 - Ignition delay time $t_v < 60ms$



8.1.3 Differences between both pressure measuring channels

The different sensitivity of the pressure transducers requires an adjustment of the calibration data.

Have the pressure transducers been interchanged by mistake?

Do the settings of the calibration data match the calibration sheet?

See: [2. Software / Setup 4: Apparatus](#)

Has the silicone protective layer on the pressure transducers hardened or even broken?

See: [Annex: Protect diaphragm of pressure transducers](#)

Dirty insulators at the connectors cause a drift from the charge signal.

See: [8.2 Error in pressure measurement](#)



8.1.4 Igniter not activated during normal test procedure

The measurement of the ignition delay time t_v starts with the first pressure increase in the sphere.

The following therefore applies: **no pressure increase = no ignition.**

8.2 Error in pressure measurement

8.2.1 Calibration error

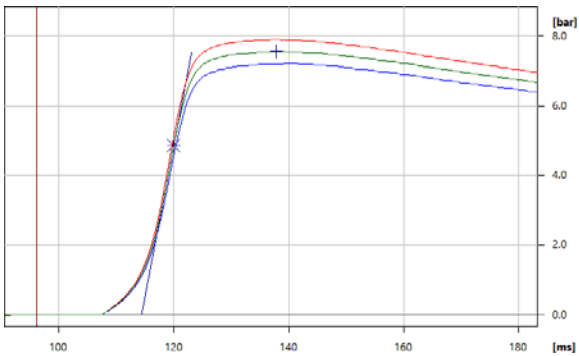

Have the pressure transducers been interchanged by mistake? Do the settings of the calibration data match the calibration sheet?

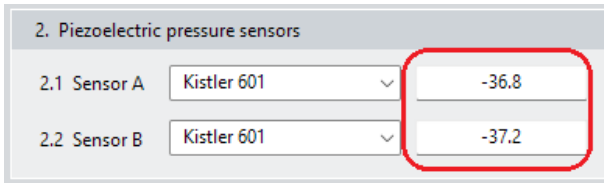
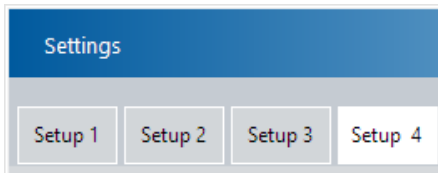

8.2.2 Error due to drift

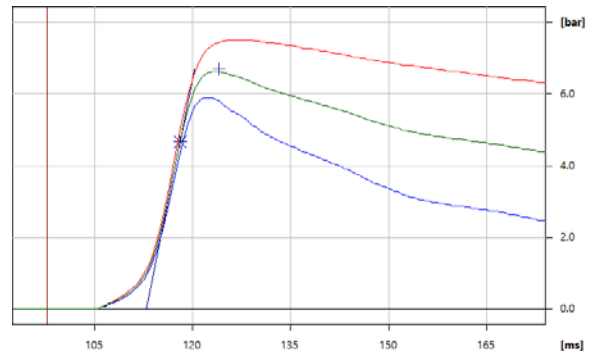

Dirty insulators in the plug-in connections of Kistler piezoelectric pressure transducers cause a drift in the charge signal.

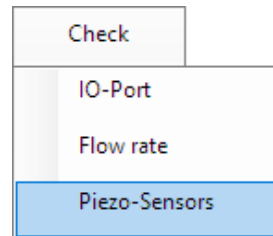

channel:	A	B	
maximum:	0.06	0.03	bar
current:	0.06	0.02	bar
minimum:	0.00	0.00	bar
drift:	0.06	0.03	bar/min

Limit for drift = 1bar/min = 0.05bar/3s

This test program measures the drift. If this is too large, the channel is displayed in red. Recommendation: rinse the connectors with a cleaning spray (Kistler No. 1001A).

8.3 Charge Amplifiers

All components are factory calibrated by the manufacturers. If malfunction is suspected, this can be checked with built-in means.

Dynamic pressure measurement:

The sensitivity of the pressure transducers [pC/bar] is set digitally via IO-Link.

The system consists of 2 independent measuring channels. As long as both match, it can be assumed that the measured values are correct. If there is no agreement, the charge amplifier can be easily checked. To do this, connect the measurement input to the "Test" output, select "Test charge amplifier" and start the procedure.

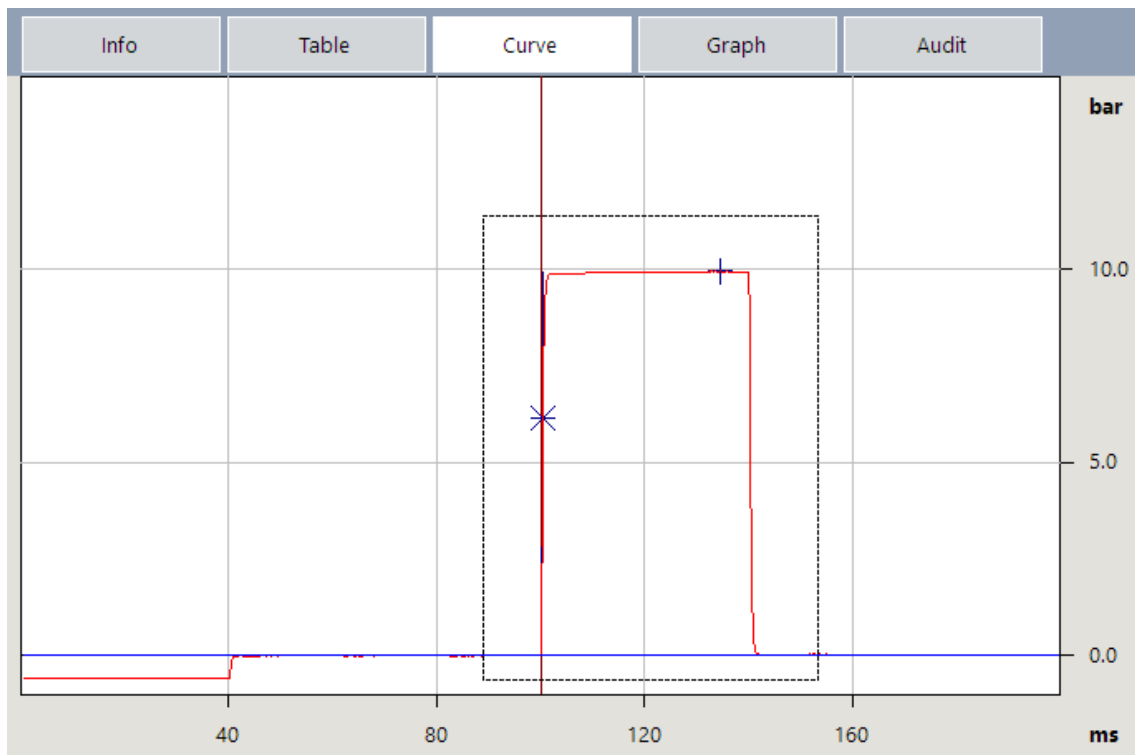

P_{ex} must then be 10.0 bar ± 0.2 bar.

This test with a rectangular charge signal also shows that the measuring system is quite capable of measuring a dP/dt of 20'000 bar/s.

P_{ex}	10.0	bar
P_m	10.9	bar
dP/dt	23435	bar/s
P_d	0.59	bar
t_d	40	ms
t_v	60	ms

9. Maintenance

9.1 Update

The “**Update**” menu is only available to users with administrator or service rights.

The update is performed automatically. Existing software settings are retained.

A Your PC is connected to the internet. The update can be carried out immediately:

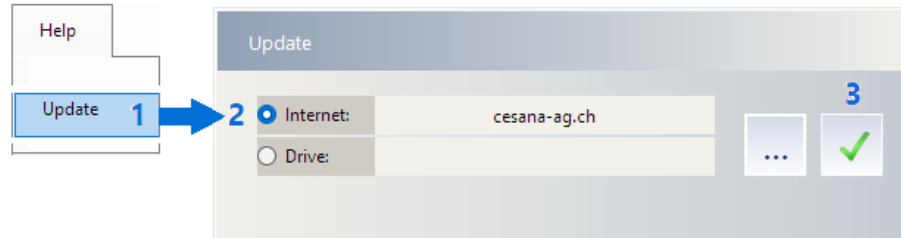

B Your PC is not connected to the internet::

Send an e-mail to: info@cesana-ag.ch

You will receive a link from us for downloading the file(s).

Extract the file “**CAG_Updates.zip**” into a temporary directory or on a USB stick.

1. Start the update in the MIKE program.
2. Select “**Drive**” as the update source.
3. Search for the “**Updates**” directory.
4. Start the update.

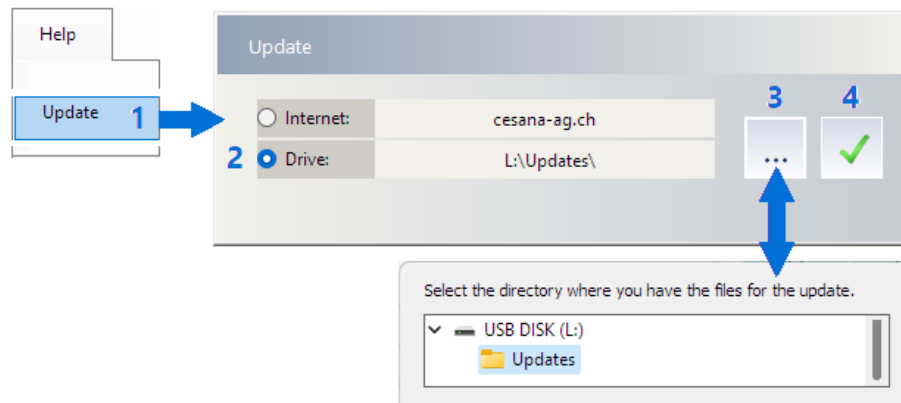

Participants in the annual CaRo calibration ring trial receive a USB stick with the latest software updates. Then enter the directory with the USB stick, e.g. **L:\Updates** in the **Drive** field and start the update.

9.2 Flash Programmierung

If the following message appears after an update, the flash program needs to be updated.

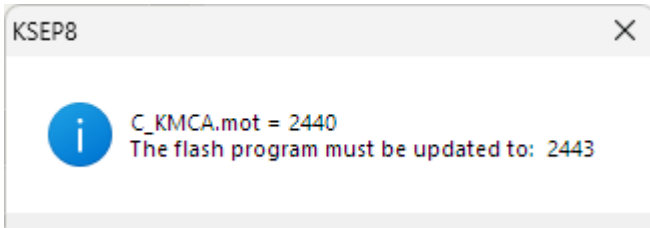

The “*CAN modules*” menu is only available to users with administrator or service rights.

Procedure:

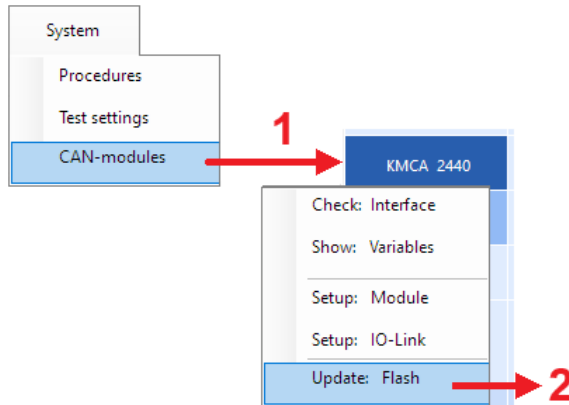

Search for flash file *C_KMCA.mot*.

flash	pcb - board	identity	revision
current	KMC81A	C_KMCA	2440

3

Open the latest flash file

filename	date	size
C_KMCA.mot	24.12.2024	115 KB

4

The flash files are usually in the KSEPP8 program directory.

Compare revision date and if newer, program this file.

flash	pcb - board	identity	revision
current	KMC81A	C_KMCA	2440
new	KMC81A	C_KMCA	2443

filename	lines loaded	lines written	time
C_KMCA.mot	2398	0	00:00

5

flash	pcb - board	identity	revision
current	KMC81A	C_KMCA	2440
new	KMC81A	C_KMCA	2443

filename	lines loaded	lines written	time
C_KMCA.mot	2398	463	00:22



pcb-board and *identity* must be of the same type.
(revision = year / week)

9.3 IO - Port

Check
IO-Port
Flow rate
Piezo-Sensors

This test program allows direct access to all inputs and outputs.

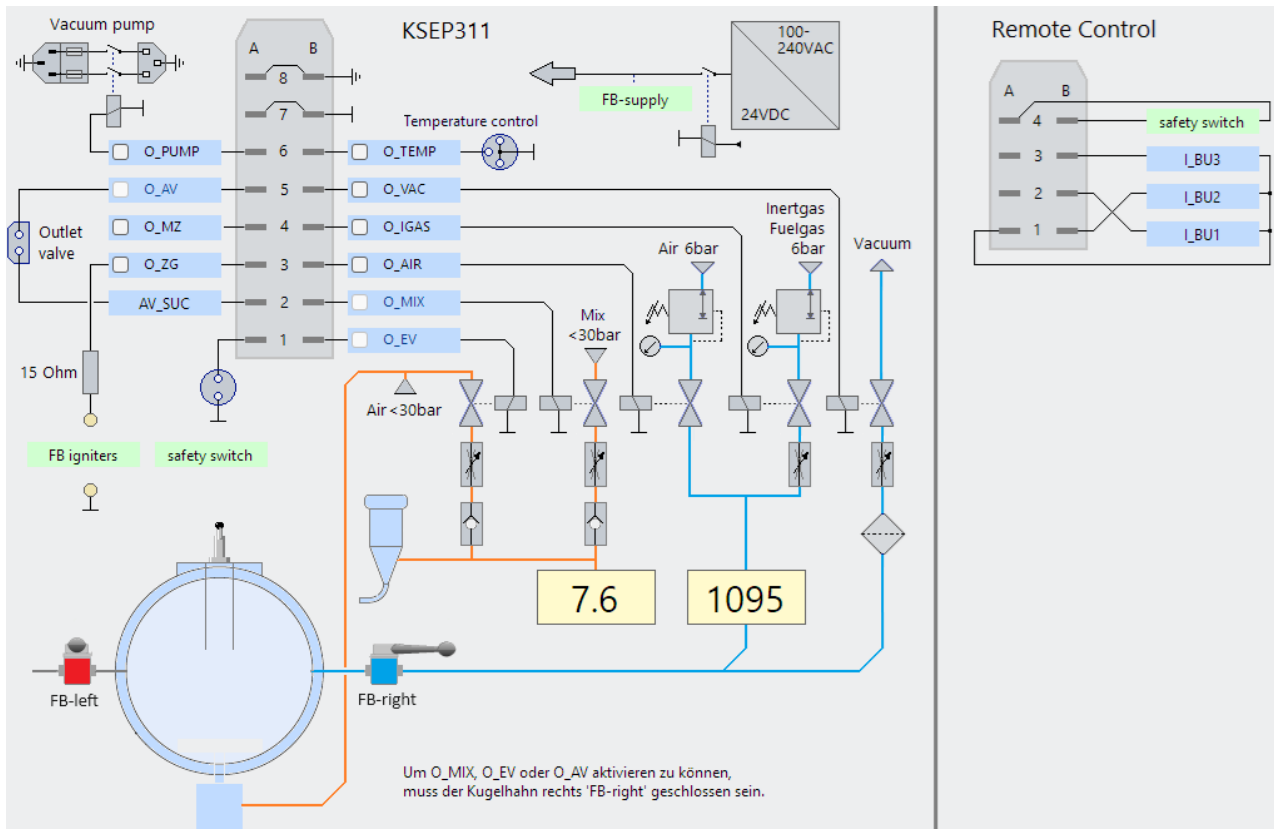

The exhaust valve (O_AV) is not designed for 100% duty cycle. Its activation is therefore automatically limited in time.



The function of the safety switch and emergency stop on the remote control are deactivated. Therefore, caution: **All compressed air connections must be depressurized!**

9.4 Flow rate

Check
IO-Port
Flow rate
Piezo-Sensors

The automatic preparation of the tests is done via solenoid valves. In doing so, times for pressure equalization between the sphere or pre-chamber and their pressure transducers are observed. Thermally induced pressure changes are also taken into account.

Minimal switch-on times for the solenoid valves require a reduction in flow rate in order to maintain the required accuracy.

This program shows the flow rates for setting them to the recommended values using the needle valves built into the KSEP311. The flow rate is directly dependent on the pressure difference. Therefore, the recommended flow rate should be set at the corresponding pressure.

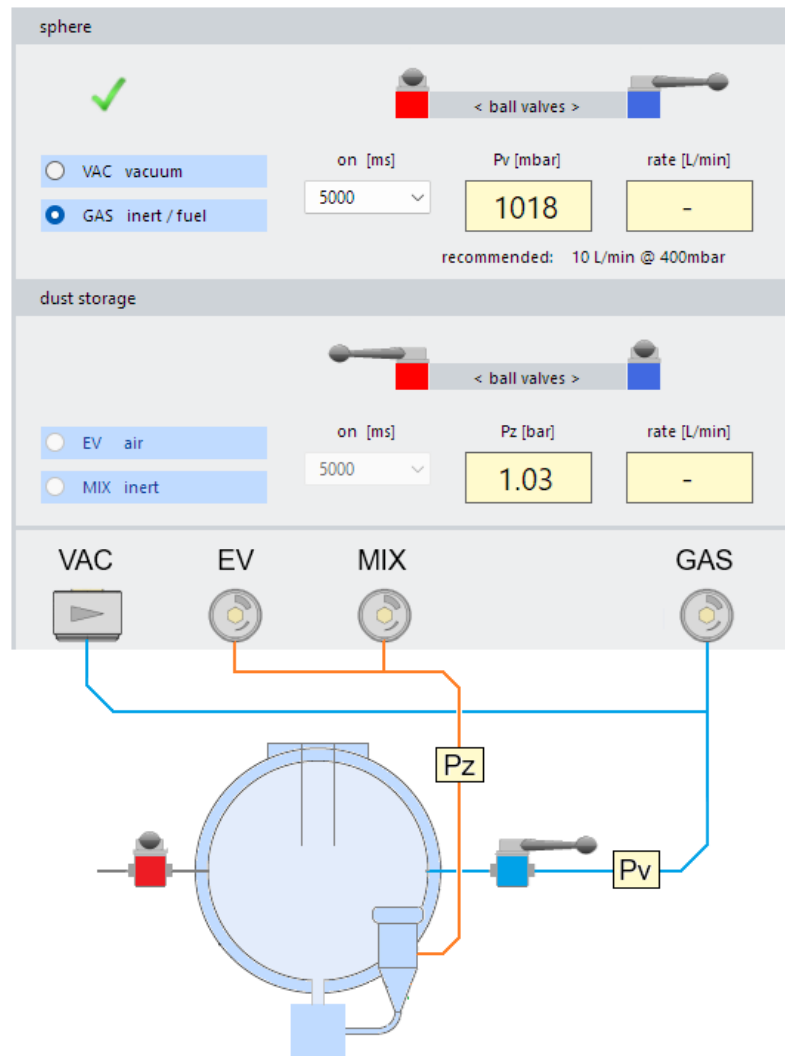

Recommended:	VAC	Vacuum	-20 L/min at	400mbar
	GAS	Inert- or Fuel-Gas	10 L/min at	400mbar
	MIX	Inertgas	1 L/min at	10bar
	EV	Air (Inlet-Valve)	2 L/min at	10bar



Excessive flow reduces the accuracy of the automatic preparation. However, a tolerance of $\pm 20\%$ is permissible.

9.5 Setup: Module

Prerequisite: User with administrator or service rights.

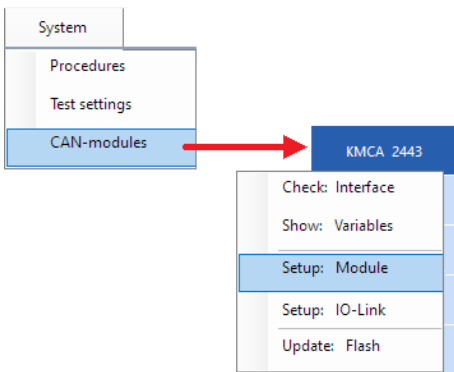

The screenshot displays the software interface for the KMCA 2443 module. On the left is the 'Input / Output' list with checkboxes for various functions. The main area is divided into calibration sections for Temperature and LV. The 'KSEP333 - Setup' section contains fields for serial number, unit, first setup, calibrated date, PCB revision, and number. A status bar at the bottom shows 'KMC - Status + Parameters' with an 'ok' indicator.

Parameter	Value
current [°C]	31.9

Parameter	LV_A	LV_B
Px [bar]	-	-
Px [adc]	-	-
adc offset	154.34	134.37
adc gain	2.5033	2.5125
impulse	-84.9146	-84.7578

Field	Value	Field	Value
Serial no	100300	unit	2
first setup	30.03.2022	by	CC
Calibrated	03.01.2023	by	CC
Pcb - rev	2210	number	2

RELAY...
O_AV...

must be activated for the function of the inputs and outputs.

is automatically limited in time to avoid overheating of the valve.

Instructions for calibration of temperature and LV, see: [B081_500.pdf](#)

9.6 Setup: IO-Link

Prerequisite: User with administrator or service rights.

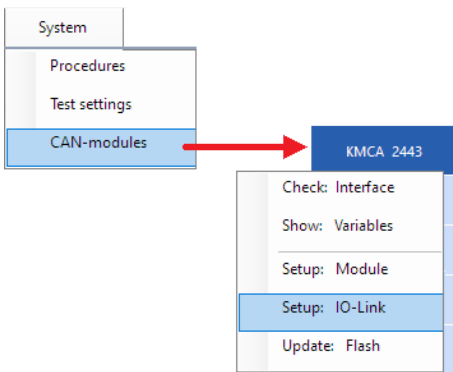

LV A	LV B	Pz (PXA)	Pv (PXB)
Vendor ID	Vendor ID	Vendor ID	Vendor ID
0x023F	0x023F	0x0011	0x0011
Device ID	Device ID	Device ID	Device ID
0x502806	0x502806	0x000700	0x000700
Serial no.	Serial no.	Serial no.	Serial no.
6299223	6299224	S4025E0116C	S4025F0116C
Cycle time	Cycle time	Cycle time	Cycle time
800us	800us	3100us	3100us
Min. cycle	Min. cycle	Min. cycle	Min. cycle
600us	600us	2500us	2500us
PDin value (raw)	PDin value (raw)	PDin value (bar)	PDin value (mbar)
-1	0	1.02	1011.5
PDin scale (10E)	PDin scale (10E)	Control	Control
-3	-3	0x4F 0x01	0x4F 0x01
PDin option	PDin option	FUNC: 0=off	FUNC: 0=off
0	0	0	0
Control	Control	UNI: 0=bar, 2=psi	UNI: 0=bar, 2=psi
0x4F 0x00	0x4F 0x00	0	0
Units (2=bar)	Units (2=bar)	ZRO: zero point	ZRO: zero point
2	2	0	0
Sensitivity (pC/bar)	Sensitivity (pC/bar)	TAU: damping (0.1s)	TAU: damping (0.1s)
-170	-170	0	0
Range (bar)	Range (bar)	STL: value for 4mA	STL: value for 4mA
20	20	0	0
Range analog (V)	Range analog (V)	STU: value for 20mA	STU: value for 20mA
10	10	40000	2000
Active (0=H, 1=L)	Active (0=H, 1=L)	DRO: 1=display 180°	DRO: 1=display 180°
1	1	0	0
LP-filter (0=off)	LP-filter (0=off)	FH1: SP1 on [mbar]	FH1: SP1 on [mbar]
0	0	25000	2000
Time const. (0=off)	Time const. (0=off)	FL1: SP1 off [mbar]	FL1: SP1 off [mbar]
0	0	23000	1950
Operating hours	Operating hours	STA: Diagnostic	STA: Diagnostic
63	65	0000	0000



Are individual parameters marked with a red field?

Then set this device to "default" values.

Exception: *Sensitivity (pC/bar)* may vary depending on the sensor.

10. References

VDI-GL 2263	Staubbrände und Staubexplosionen, Gefahrenbeurteilung und Schutzmassnahmen, Beuth-Verlag GmbH, Berlin und Köln, 1986
W. Bartknecht	Dust Explosions; Course, Prevention, Protection Springer Verlag, Berlin, Heidelberg, New York 1989
R. Siwek	Explosion Characteristics and Influencing Factors, International Symposium on Control & Prevention of Dust Explosions Basel, 1982
ISO/DIS 6184/1	International Standard "Explosion Protection Systems", Part 1: Test methods for the determination of explosion indices of combustible dusts in air"
R. Siwek	Reliable Determination of the Safety Characteristics in 20-I-apparatus. Symposium on Flammable Dust Explosion; St. Louis Missouri, USA, 1988
W. Bartknecht	Explosionsschutz; Grundlagen und Anwendung Springer Verlag, Berlin, Heidelberg, New York 1993
G. Pellmont	Explosions- und Zündverhalten von hybriden Gemischen aus brennbaren Stäuben und Brenngasen. Dissertation ETH Zürich, Nr. 6498, 1979
T. Glarner	Temperatureinfluss auf das Explosions- und Zündverhalten brennbarer Stäube, Dissertation ETH Zürich, Nr. 7350, 1983
T. Glarner	Mindestzündenergie - Einfluss der Temperatur VDI-Berichte Nr. 494, Seite 109-118, 1984
R. Siwek Ch. Cesana	Assessment of the fire and explosion hazard of combustible products for unit operations; Butterworth - Heinemann, International conference, Singapore, 1993
R. Siwek Ch. Cesana	Ignition behaviour of Dusts 28th Loss Prevention, Atlanta, 1994
R. Siwek Ch. Cesana	Methods for Determination of the Explosion Characteristics according to international Standards, Proceedings of the „First International Seminar on Fire and Explosion Hazard of Substances, Venting of Deflagrations“, July 17-21, Moskau, Russia, 1995
EN 14034-1	Bestimmung der Explosionskenngrossen von Dust/Luft-Gemischen Teil 1: Bestimmung des maximalen Explosionsdruckes p_{max} September 2004
EN 14034-2	Bestimmung der Explosionskenngrossen von Dust/Luft-Gemischen Teil 2: Bestimmung des maximalen zeitlichen Druckanstiegs $(dp/dt)_{max}$ Mai 2006
EN 14034-3	Bestimmung der Explosionskenngrossen von Dust/Luft-Gemischen Teil 3: Bestimmung der unteren Explosionsgrenze UEG Mai 2006
EN 14034-4	Bestimmung der Explosionskenngrossen von Dust/Luft-Gemischen Teil 4: Bestimmung der Sauerstoffgrenzkonzentration SGK September 2004